

CLARITY
FUEL CELL

Press Information | March 2017





Honda Leading Towards a Hydrogen Society

Having identified hydrogen as a potential solution to the environmental issues faced by society, Honda began basic research on fuel cells as early as the late 1980s. In 2002, Honda became the first automaker in the world to receive approval by the U.S. government to sell fuel cell vehicles, and began leasing them in the U.S. and Japan. In 2008, Honda began leasing the FCX Clarity to consumers; it featured a dramatically advanced fuel cell stack, innovative sedan package, and a new dimension of driving feel. In 2016, Honda reached an even greater height with the next evolution of its fuel cell technologies.

The all-new 2017 Clarity Fuel Cell is an even more compelling vehicle that offers greater practicality than previous fuel cell vehicles. The Clarity Fuel Cell can be used on a daily basis just like a traditional gas-powered vehicle, but provides much more driving enjoyment and zero emissions. Honda is stepping into a new era with the aim of popularizing fuel cell vehicles. Honda also wants to create a movement towards a hydrogen society. Honda has already built an array of hydrogen technologies--technologies to "produce, use and connect" hydrogen--through the Clarity Fuel Cell project and the development of hydrogen stations and external power export devices.

Honda continues to take on challenges to open the door to greater possibilities of hydrogen, to harness the joy of free mobility and realize a rich, sustainable society. On the way to realizing "the Joy and Freedom of Mobility" and "a Sustainable Society where People Can Enjoy Life," Honda is committed to advancing hydrogen technologies leading to a fully-fledged hydrogen society.

CLARITY FUEL CELL



The Clarity Fuel Cell is the first in the Clarity series of all-new electrified vehicles from Honda. Built on a common platform, the Clarity series also will include the Clarity Electric (BEV) and Clarity Plug-in Hybrid (PHEV) as Honda works to evolve and popularize electrified vehicles. Every electric vehicle on the market today has at least one barrier to overcome, whether size, affordability, range or recharging/refueling. The strategy behind the Clarity series addresses these issues through its spacious five-passenger cabin, focus on increased affordability, and expanding infrastructure. To achieve mass-market appeal, Honda's product development pathway is aimed toward future full-scale mass production, rather than focused on a narrow group of users. To that end, Honda selected the "3-in-1 concept" that mounts the fuel cell powertrain under the hood like a conventional gasoline or hybrid vehicle, and realizes BEV and PHEV variants using the same platform, making Clarity the first vehicle in the industry to offer fuel cell, BEV and PHEV powertrain options on a single platform. This shared platform strategy will enable Honda to respond to infrastructure and market developments, provide customers nationwide with an ultra-low carbon vehicle that meets their lifestyle needs, and takes Honda toward higher volume sales of advanced powertrain products that will help to realize our dream for an ultra-low carbon mobility future.

● Clarity Electric

The Clarity Electric will be geared toward commuters who desire all-electric performance in a spacious, comfortable and premium-contented five-passenger sedan that fits their daily driving needs.

● Clarity Fuel Cell

Honda views fuel cells as the ultimate zero-emissions vehicle technology and the Clarity Fuel Cell offers early adopters the latest technology to be on the forefront of "what is next" while enjoying the convenience of short refueling times and the flexibility and confidence of a 366 mile EPA range rating*, the longest of any zero-emissions vehicle.

● Clarity Plug-In

The Clarity Plug-In hybrid will be the volume leader of the series, marketed in all 50 states, and having an anticipated all-electric driving range rating in excess of 40 miles and a total driving range comparable to that of a traditional gasoline-powered sedan.

*Based on 2017 EPA range rating. Use for comparison purposes only. Your range will vary based on how you drive and maintain your vehicle, driving conditions, powertrain condition, and other factors.

Honda Is Taking Proactive Steps to Solve Environmental Issues.

What Honda Is Doing to Address Environmental Issues

Honda has long been at the forefront of research on environmental issues facing the automobile industry. For example, Honda was the first manufacturer to meet the Clean Air Act of 1972 without the use of a catalytic converter by developing the CVCC engine. Since then, Honda has introduced numerous cars and technologies to further reduce emissions.

In its fight against global warming, Honda is working to minimize CO₂ emissions by pursuing greater thermal efficiency for engines, developing hybrid systems, and other fuel efficiency-improving technologies.

In addition to these efforts, Honda is also working to curb society's dependence on fossil fuels such as petroleum, one of the largest sources of harmful emissions. To this end, Honda is investing in the research and development of next-generation clean vehicles. They include plug-in hybrids (PHEVs) that minimize the use of gasoline, battery electric vehicles (BEVs) that use electric power instead of fossil-derived energy and fuel cell vehicles (FCVs) that generate electricity from hydrogen.

Reducing CO₂ Emissions on a Global Scale

As emerging nations undergo a motorization boom and vehicle production increases around the world, the international society is imposing stricter requirements on environmental performance of vehicles every year. One projection based on the Energy Technology Perspectives (ETP) published by the International Energy Agency (IEA) forecasts the global CO₂ emissions from transportation vehicles to nearly double from the 2010 level by 2050 due to growth in emerging nations, among others (see 6DS*¹ in the graph on the right), and sets a target of reducing at least 60 percent of the CO₂ emissions anticipated in 2050 (see 2DS*² in the same graph). In light of this, the auto industry must introduce various types of next-generation clean vehicles fueled by diverse energy sources like FCVs, BEVs and PHEVs, to curb CO₂ emissions.

*1 6DS = Scenario where the current economic growth will continue and the temperatures will rise by as much as 6 degrees celcius over time, to significantly affect the lives of people.
 *2 2DS = Scenario where sustainable energy systems will reduce the GHG and CO2 emissions and keep the rise in temperatures to 2 degrees celcius or less over time.

Environmental Initiatives

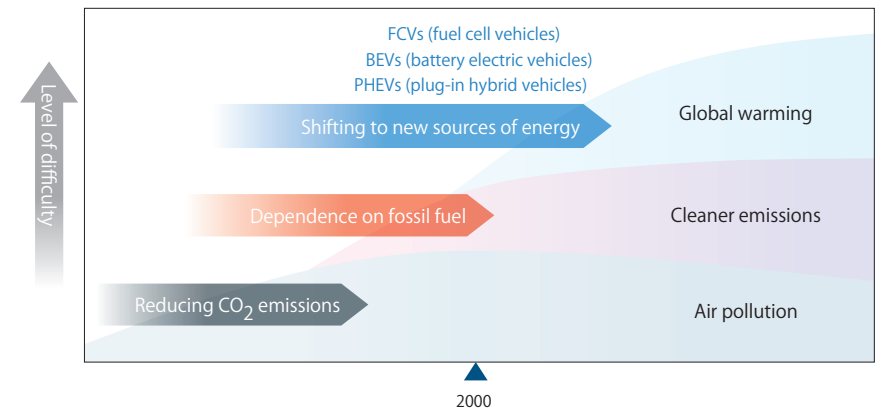

Reduction of CO₂ Emissions and Diversification of Energy Sources

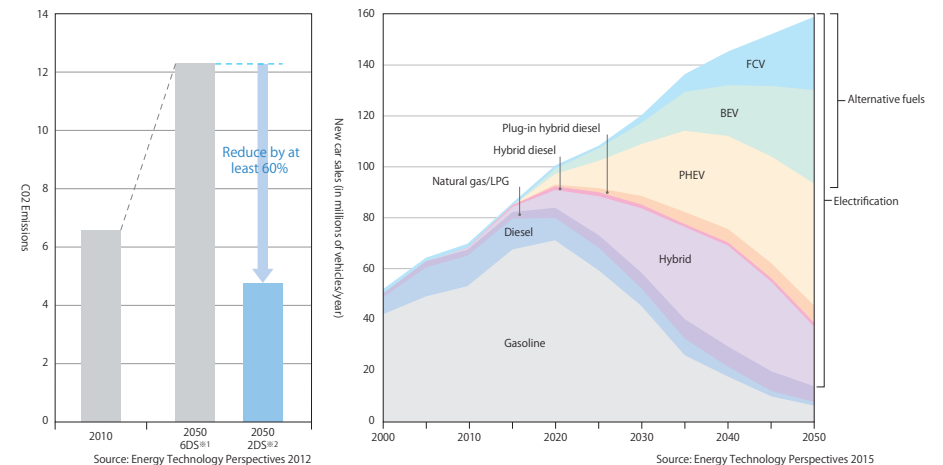

Honda Is Developing Various Clean Vehicles to Increasingly Reduce CO₂ Emissions

Honda's Next Generation Clean Vehicles

Honda is working to develop various next-generation clean vehicles meeting the needs and usage requirements of today's consumers in order to reduce global CO₂ emissions.

PHEVs drive like an electric vehicle when traveling short distance in cities, but behave like a conventional hybrid vehicle when the battery level drops or on expressways for example, thereby minimizing the use of gasoline. On the other hand, BEVs and FCVs are so-called "zero emission cars" that do not emit CO₂ while driving.

Battery capacity has a direct impact on driving range. For short-distance driving, Honda believes BEVs with relatively small battery capacities offer the best solution in terms of cost to the customer and the environment.

Honda believes FCVs are the ultimate clean vehicles as they release no CO₂ emissions. This is because they generate electricity from hydrogen energy while driving. Furthermore, hydrogen vehicles refuel quickly and offer similar range to a gasoline engine vehicle.

FCVs Generate Electricity from Hydrogen As They Drive.

FCVs carry a hydrogen tank instead of a gasoline tank found on conventional vehicles, and generate electricity inside the fuel cells as the hydrogen reacts with the oxygen contained in the air. This electricity, generated within the vehicle, drives the motor to move the vehicle with no CO₂ or other harmful emissions being generated. FCVs achieve ultimate clean performance as water is the only byproduct of electricity generation in the vehicle.

■ Honda's Vision for Next-generation Clean Vehicles

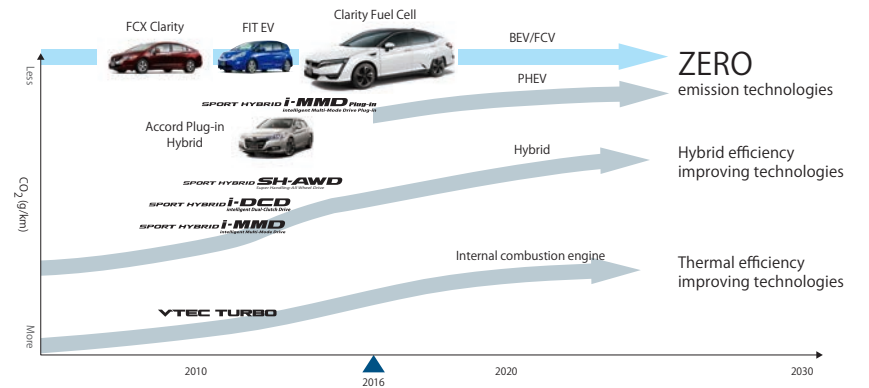

■ Structure of FCVs

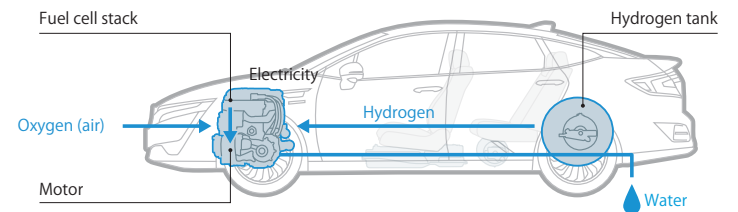

Hydrogen Has the Potential to Realize an Energy Sustainable Society.

Virtuous Circle-type Energy Not Dependent on Fossil Fuel

Hydrogen does not exist independently on Earth, but is contained in various substances from which it can be extracted. Hydrogen can be produced from natural gas and biomass, and also through water electrolysis using electricity generated from renewable energy such as solar, wind and hydro power.

As hydrogen can be produced in many different ways reflecting the geographical characteristics and unique weather of each region, society can look forward to establishing an ideal hydrogen cycle that is not dependent on fossil fuel.

Hydrogen Energy Can Be Produced, Transported and Stored, ready for conversion into Electricity When Needed.

Although electricity can be stored in batteries, storing a large amount of electricity is difficult. Normally electricity is generated at power plants and supplied continuously to cover anticipated usage; however, once hydrogen is produced, it can be compressed or liquefied and transported or stored in tanks. The stored hydrogen can then be converted to electricity through fuel cells to produce the necessary amount of electricity at the location where it is required. In other words, hydrogen energy offers much more flexibility in the way it can be used.

Honda Proprietary Technologies to Create a Hydrogen-based Society.

Hydrogen for vehicle use can be produced using renewable energy and then transported or stored. Honda saw opportunities in these characteristics and built unique hydrogen technologies to realize a hydrogen society. Hydrogen is produced at a space-saving, easy-to-install smart hydrogen station using solar power and other methods. This hydrogen is then available to fuel FCVs that will use it to generate electricity as they drive. These FCVs can also function as small power stations, or mobile power supplies, and connect and supply electricity to portable external power export devices, homes or facilities. FCVs expand the possibilities of hydrogen energy, as they can also be utilized as an emergency power source in natural disasters.

■ Circulation-type Energy

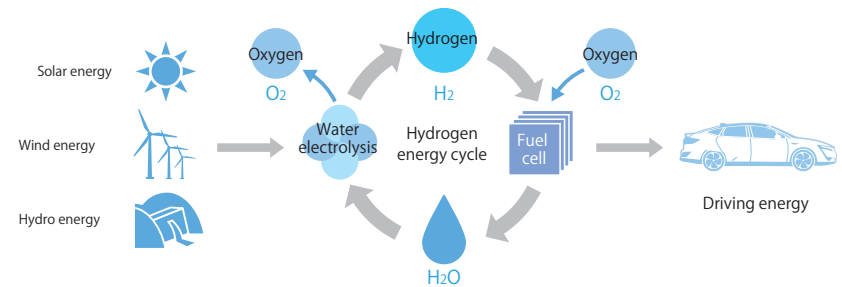

■ Characteristics of Hydrogen

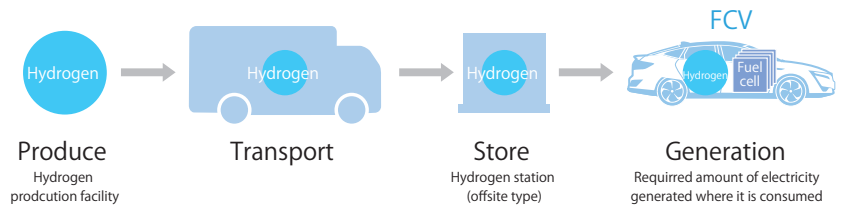

■ Hydrogen Technologies Honda Is Developing

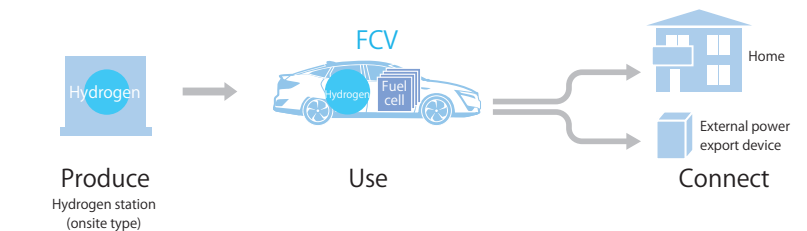

Honda Has Achieved a Big Step in the Popularization of FCVs. The Evolution of Fuel Cell Stacks Was the Key to Success.

Smaller, Higher-performance Fuel Cell Stacks.

Honda began basic research on fuel cells in the late 1980s, which progressed to research on fuel cell vehicles a decade later. In the first prototype, based on an Odyssey minivan, the fuel cell system occupied most of the cabin space, barely leaving room for the driver. More research followed and in 1999, Honda premiered a test vehicle carrying a fuel cell stack (FC stack) under the floor. After that, Honda worked on improving the performance of fuel cells by increasing their efficiency output and in 2003 released the Honda FC Stack capable of starting at -20 degrees celsius. Making the fuel cell smaller while achieving these performance improvements remained a constant issue and Honda took on the challenge of meeting the mutually exclusive requirements of higher output and smaller size. The previous model FCX Clarity, a four-passenger sedan released in 2008, presented one such solution. It carried a dramatically smaller fuel cell stack which was able to be packaged within the center tunnel instead of under the floor. With the new Clarity Fuel Cell, Honda successfully reduced the size of the fuel cell stack by 33 percent (compared to the previous model) by increasing the output density.

Integrated Fuel Cell Powertrain Expands Package Flexibility.

Development Began with the Traditional Five-Passenger Sedan Layout. From the early development stages, Honda aimed at a creating an attractive sedan offering a traditional five-passenger package. In the Clarity Fuel Cell, this was accomplished by not only making the fuel cell stack smaller, but also integrating it with the FCVCU and drive unit. The result is the only fuel cell sedan[†] with the powertrain packaged under the front hood. This gives the Clarity Fuel Cell greater packaging flexibility, opening the way to many possible variants in the future.

† Among the sedans scheduled for release as of February 2017. Comparison by Honda.

Evolution of Fuel Cell Stacks

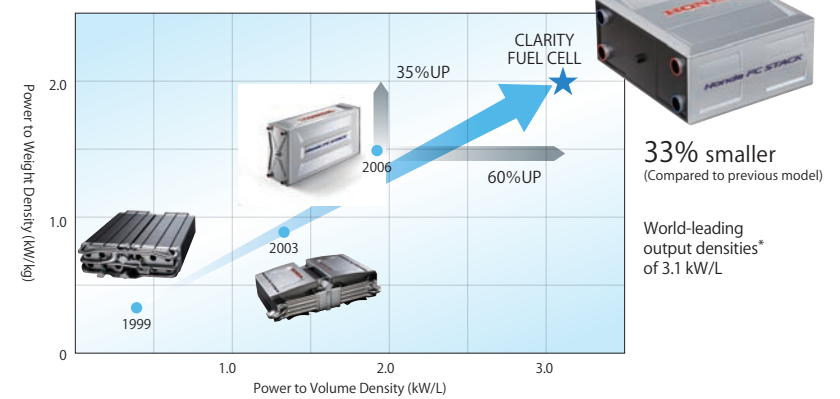

Integrated Fuel Cell Powertrain



Clarity Fuel Cell, The FCV for Everyday Use



CLARITY
FUEL CELL

Bringing Fuel Cell Vehicles into Everyday Life

Honda created a dedicated four-passenger FCV sedan with the 2008 FCX Clarity. It provided Honda with valuable feedback through data acquisition as well as insights on customer needs, for future development purposes.

To truly bring FCVs into everyday life, the next step is to make FCVs a viable alternative to gas-engine vehicles. Namely, zero emission vehicles that fit the needs of the Honda customer.

The idea was to develop a fuel cell vehicle providing even more sedan-like versatility and ease-of-use together with the excitement and driving pleasure worthy of a car for the new age. To this end, development work centered on further enhancing utility and other universal sedan values and adding futuristic appeal befitting of a vehicle for a new era.

First, to achieve such universal values, we made the fuel cell stack smaller and combined it with a drive unit also reduced in size, and installed the resulting fuel cell powertrain under the front hood to create the world's first*¹ five-seat FCV sedan. In addition, the EPA range rating is 366 miles*², the longest of any zero emissions vehicle*², while the hydrogen refueling time was reduced to just 3-5 minutes*³. These improvements make the Clarity Fuel Cell as easy to use as any conventional engine vehicle.

The creation of the above mentioned futuristic appeal includes the development of an exterior design combining road presence with advanced aerodynamics; a well-appointed interior with advanced air quality management; interfaces connecting driver, car, and society; a quiet yet powerful and smooth driving feel that only a FCV can provide; and a highly responsive sport mode further enhancing the driving experience.

As a symbol of the coming of age of fuel cell vehicles, Clarity Fuel Cell welcomes driver and passengers alike to a new sense of hospitality on our journey toward making fuel cell vehicles part of everyday life.

Kiyoshi Shimizu, Project Leader



Kiyoshi Shimizu
 Chief Engineer, Automobile R&D Center, Honda R&D Co., Ltd.
 Joined Honda R&D Co., Ltd. in 1984
 Began designing FCV powertrains in 1997 after developing engines and electric powertrains
 Appointed Manager of FCV Powertrain Development Department in 2005
 Assigned to Honda R&D Americas in 2007 to conduct ZEV (zero emission vehicle) research
 Appointed LPL in charge of the Clarity Fuel Cell in 2013
 Loves yachts and is the proud owner of "Dream Quest"
 Drives a N-Box

A New Vehicle for a New Era Red Carpet to a New Era

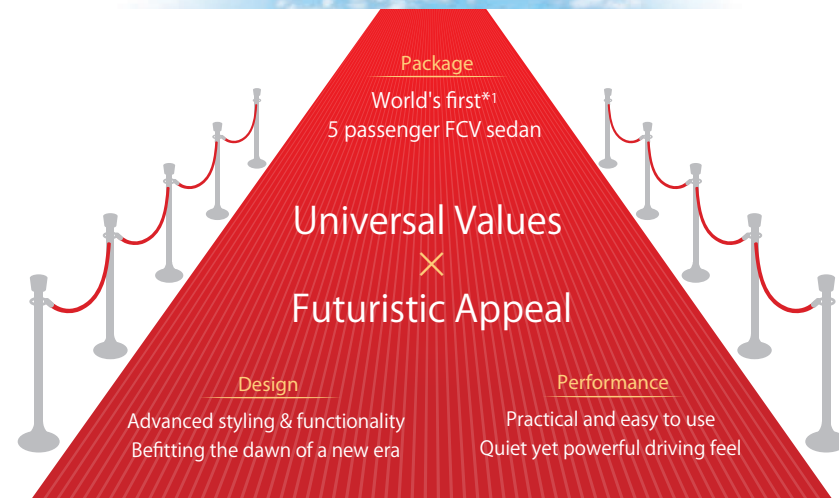

*1 As of February 2017. Comparison by Honda.

*2 Based on 2017 EPA ratings. Use for comparison purpose only. Your range will vary based on how you drive and maintain your vehicle, driving condition, powertrain condition, and other factors.

*3 Measured by Honda charging from a station at a hydrogen charge pressure of 70 MPa based on the standard condition specified by the SAE standard (J2601). The charge time varies depending on the hydrogen charge pressure and ambient temperature.

Cutting-edge Technologies Incorporated into the New Clarity Fuel Cell

Universal Values x Futuristic Appeal

PACKAGING

- 10 Comfortable sedan packaging designed with a focus on space and comfort
- 11 Compact fuel cell powertrain supporting the low roof line sedan packaging
- 12 Refining Honda's original wave flow channel and "one cooling layer per two cell structure" led to a significantly more compact fuel cell stack
- 13 Advanced fuel cell stack with impact resistance and productivity maximized for full-scale mass production
- 14 Air supply system with electric turbo air compressor and simple, compact hydrogen supply system
- 15 Combining a voltage booster to a high power, compact drive unit for increased performance
- 16 Larger capacity battery and hydrogen tanks in a compact, under-the-floor package

DESIGN

- 17 Classic sedan proportions incorporating futuristic styling cues
- 18 Polished aerodynamic styling based on a traditional sedan shape
- 19 Advanced and beautiful body colors
- 19 New wiper mechanism with smart clear wipers achieving improved cleaning efficiency
- 20 Relaxing interior you won't want to leave
- 21 Information display functions that excites the driver
- 22 Safety and comfort FCV functions connecting man and machine
- 23 Comfortable space designed with consideration to passenger well-being and environmental responsibility

PERFORMANCE

- 24 Exhilarating driving feel with direct acceleration response
- 25 Longest driving range rating of any zero-emission vehicle makes Clarity viable for everyday use
- 26 Lightweight, Low Center of Gravity Chassis Gives Supple, Direct Driving Feel
- 27 Next-generation body features lightweight materials, achieving high standards for comfort, driving and safety performance

SAFETY

- 28 Crash safety based on dedicated electrified vehicle platform
- 29 Honda Sensing™ -- advanced driver-assistive technologies on the road towards a "collision-free society"

Comfortable Sedan Packaging Designed with Focus on Space and Comfort

Low & Wide Sedan Form Allowing Comfortable Room for Five People

With Clarity, Honda aimed to achieve a balanced package meeting various situations from day-to-day driving to long-distance travel. The fuel cell stack, which was placed in the center tunnel in the previous model, was made significantly smaller and housed under the front hood, thereby achieving a highly efficient layout and larger cabin space. The benefits include the low roof line and driving position typical of a sedan, interior space that can comfortably accommodate five adults, and ample luggage space.

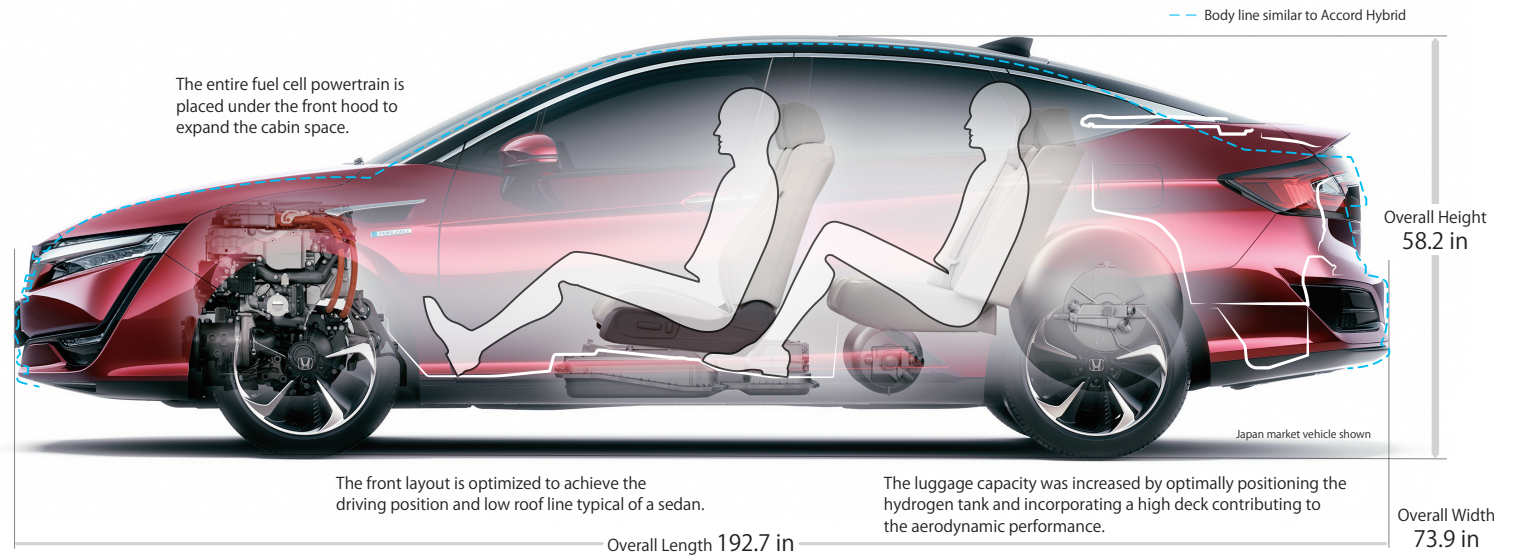

Driving Position Typical of a Sedan and Spacious Rear Seat

Carrying the battery under the front seat, the Clarity Fuel Cell achieves the driving position of a traditional sedan by reducing the height difference between the pedal and hip point through innovative battery shape and body structure. The rear seat boasts a tandem distance equivalent to that of the Accord Hybrid, more shoulder room than a Lexus LS, and ample leg room achieved by optimized front seatback shape and layout. The result is a spacious rear passenger area that can seat three people comfortably.



Luggage Space Accommodates Three Golf Bags

The double hydrogen tank configuration and multi-link rear suspension enabled the positioning of both tanks forward and low in the vehicle. Coupled with the high-deck rear styling, this resulted in 11.8 cu ft*¹ of luggage space, large enough for three 9.5" golf bags*², and similar to the 2017 Accord Hybrid.



※1 Measured by Honda based on the VDA method.
 ※2 Not applicable to all golf bags depending on the shape, size, etc.

Compact Fuel Cell Powertrain Supporting the Low Roof Line Sedan Packaging

The Entire Fuel Cell Powertrain Now Fits Under the Front Hood Improving Design Flexibility



The powertrain, comprised of the fuel cell stack and drive unit (equivalent to the engine and transmission in a conventional ICE-powered vehicle), now fits under the front hood. This permits sharing of the same package designs with conventional models and boosts mass producibility, as existing production lines can be used.

Same Compact Layout of Generation/Drive Functions Expected from a V6 Powertrain

The generation functions including the fuel cell stack and hydrogen/air supply systems, and distribution/drive functions such as the FCVCU and drive motor, are consolidated in a small space. Basic dimensions including the length, width and height are equivalent to that of a typical V6 powertrain*1.

Size Comparison of Powertrains

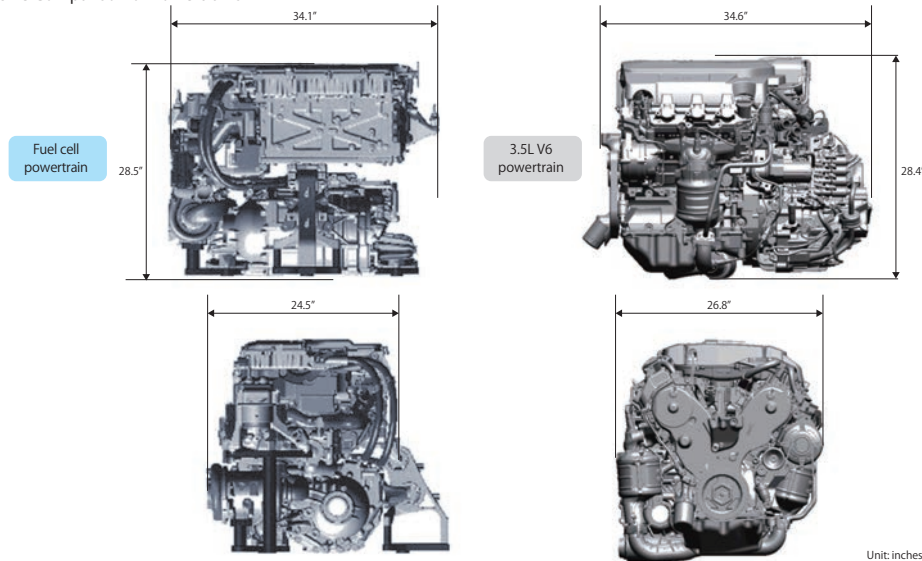

System Configuration

Fuel Cell Powertrain

Fuel Cell Stack

Hydrogen is used to generate electricity. Achieving the world's highest output densities^{*2} of 3.1 kW/L allowed a 33% reduction in dimensions compared to the previous model.

Drive Unit

Thanks to a lower-height drive unit integrating the 174hp (130-kW) high-output motor, gearbox and power control unit (PCU), the fuel cell stack is now fitted under the front hood.

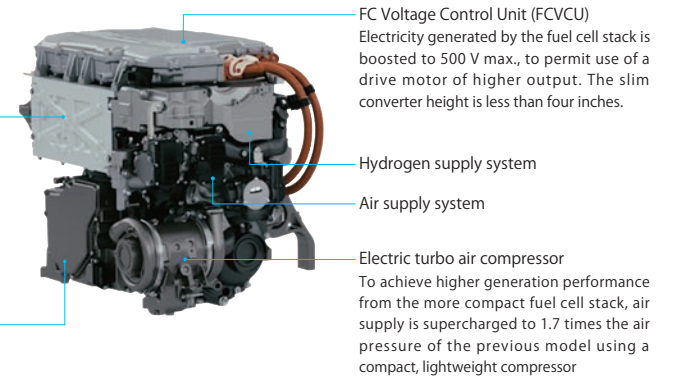

System Configuration of Previous Model

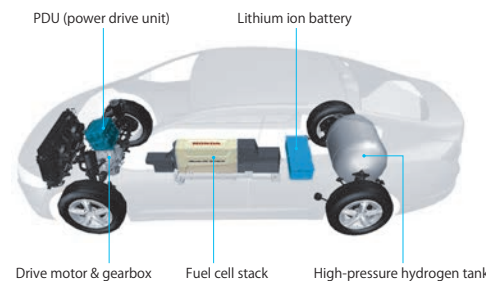

High-pressure Hydrogen Tank

Two tanks of different sizes, made with aluminum liners, are used to create a high-efficiency, large-capacity packaging with a service pressure of 10,000 psi (70 MPa)

Lithium Ion Battery

The lithium ion battery stores the electricity generated by the fuel cell stack. In situations where more power is needed, (standing starts, acceleration) electricity is supplied to the drive motor by both the fuel cell stack and the battery. Electricity generated while decelerating is stored in the battery. The lithium ion battery in the Clarity Fuel Cell has excellent charge/discharge characteristics to support size/weight reduction.

*1 Honda's 3.5-liter gasoline engine
*2 As of February 2017. Comparison by Honda.

Refining Honda's Original Wave Flow Channel and "One Cooling Layer Per Two Cell Structure" Led to a Significantly More Compact Fuel Cell Stack

Substantially More Compact Fuel Cell Stack Achieved by 1.5 Times Higher Generation Performance Per Cell
 Greater gas diffusion resulted in 1.5 times higher generation performance per cell and 60 percent higher volume output density. This allowed us to reduce the number of cells by 30 percent and, by also taking advantage of the thinner cell unit design, made the stack 33 percent more compact (compared to previous model).

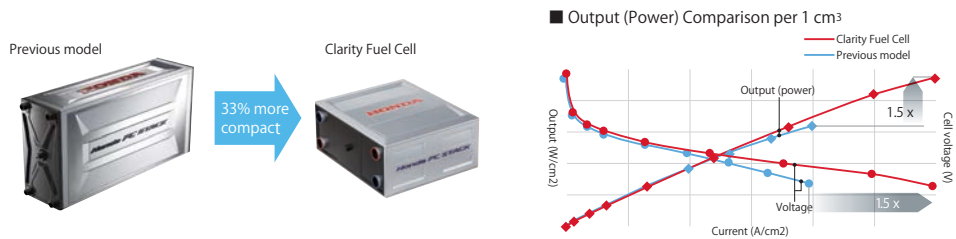

● Improved Water Circulation within the MEA to achieve higher Electricity Generation Stability

The fuel cell stack produces water on the generation surface of the air (oxygen) electrode side through chemical reaction of hydrogen and oxygen. Draining this water is important because if it stays on the generation surface, the air passage narrows and the electricity generation efficiency drops. On the other hand, the electrolytic membrane that lets the hydrogen ions pass to the air electrode side exhibits higher transmission characteristics (generation efficiency) as it absorbs more moisture. Accordingly, Honda improved the Membrane Electrode Assembly (MEA), which is the core part of the cell, and adopted a hydrogen/air counterflow design for the Clarity Fuel Cell. As a result, the humidity distribution of the generation surface becomes uniform, while the internal circulation volume of generated water is controlled accurately to maintain an optimal humidification level of the MEA according to the generation load. The result is improved electricity generation stability throughout the low to high-load ranges.

■ Gas Flow and Electricity Generation Stability

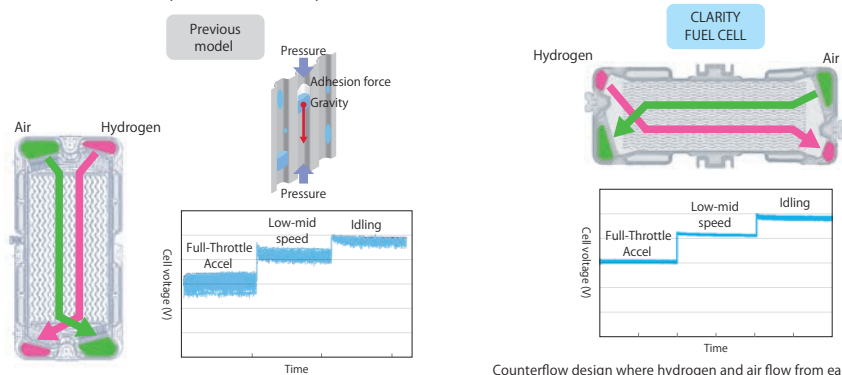

● 20 percent Thinner Cells, Plus Higher Electricity generation Performance through Improved Gas Diffusion

The cell structure within the fuel cell is made of a MEA (polymer-based laminated type electrolytic membrane) sandwiched by hydrogen/air electrode layers and gas diffusion layers, with separators having hydrogen/air and coolant flow path. Among other original technologies, Honda's fuel cell stacks adopt a wave-type (shape) gas flow path that achieves improved gas diffusion, as well as a cooling structure where two MEAs and three separators constitute one two-cell unit, to achieve size reduction. For the Clarity Fuel Cell, this structure was refined further. Improved MEAs, counterflowing gases and more uniform water distribution, which in turn allowed for shallower gas flow path and resulted in 20 percent slimmer cells with a thickness of just 1 mm per cell. The thinner separators not only made the gas flow path shallower, but narrower as well, allowing gas to diffuse better. The result is dramatically higher electricity generation performance per cell.

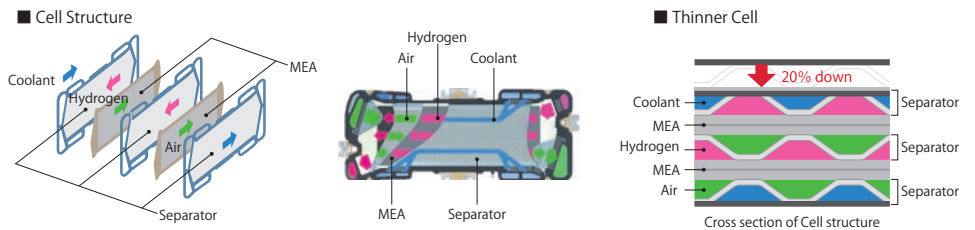

■ Narrower Gas Flow Path

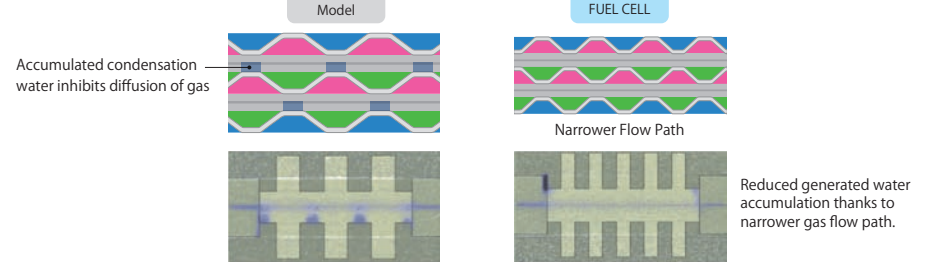

● Further Improvement of Electricity generation Performance at Low Temps

The smaller fuel cell stack led to substantially lower thermal capacity, and the MEA improvement resulted in lower cell resistance. As a result, the time to reach 50 percent output after start was roughly halved in a low-temperature environment.

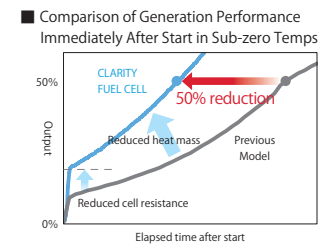

Advanced Fuel Cell Stack with Impact Resistance and Productivity Maximized for Full-scale Mass Production

Cell Retention Structure Achieving Four Times Higher Impact Resistance

With the Clarity Fuel Cell, packaging the fuel cell stack under the front hood necessitates a higher impact resistance in a forward collision compared to the previous model, with the stack located in the center tunnel. Accordingly, a fastening bar was added to connect the left and right end plates of the fuel cell stack. The convex shape of the cells and matching concave cross-section of the fastening bar, prevent the cells from shifting upon impact and causing a hydrogen leak.

■ Impact-resistant Cell Retention Structure

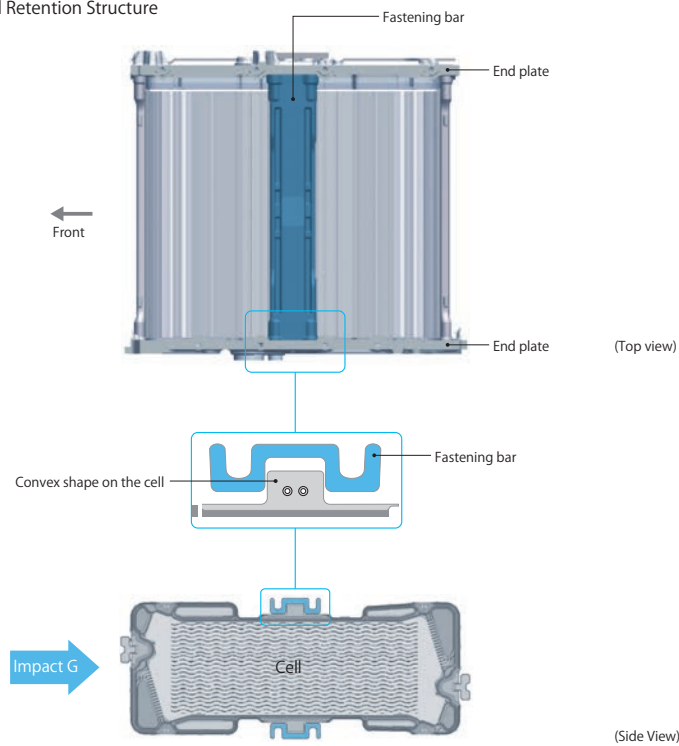

The cells are retained by the fastening bar so that the cells do not shift forward upon impact. This resulted in four times higher impact resistance compared to the previous model.

Improved Productivity and Lower Cost through Higher Material Utilization & Efficient Production

The use of resin frames (other than for the electricity generation part) and adoption of rectangular MEAs allowed for continuous coating of catalyst and fewer pieces wasted, reducing the usage of expensive materials by approximately 40 percent compared to the previous model. This contributes to the fuel cell stack production improvement and reducing cost. Adoption of resin frames also helped achieve an optimal gas distribution structure for both the hydrogen and air electrodes.

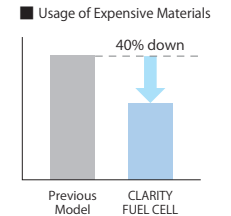

■ MEA Structure

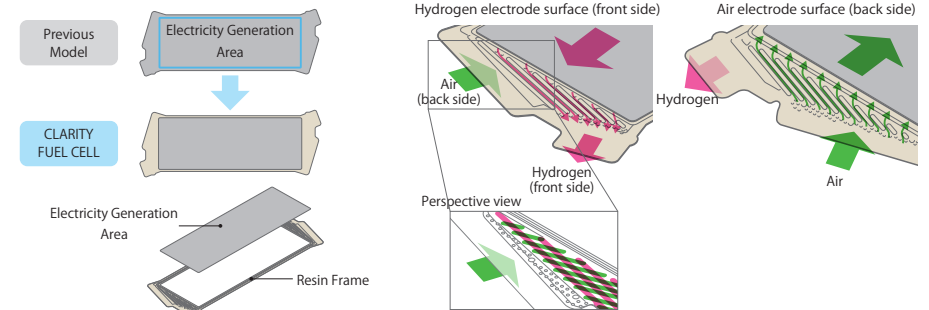

● Dramatically Improved Productivity from Continuous Printing of Gas Diffusion Layers and Electrode Layers

The rectangular shaped electricity generation area of the MEA makes the cutting process of the gas diffusion layers and electrode layers simpler, which in turn improves productivity substantially. The hydrogen electrode is composed of a gas diffusion layer, a microporous layer and an electrode layer printed in succession for increased production speed. This eliminates the piece-by-piece cutting process, reducing man-hours, while substantially improving material utilization. All these contribute to a significant cost reduction.

■ Comparison of Production Processes (Hydrogen Electrode)

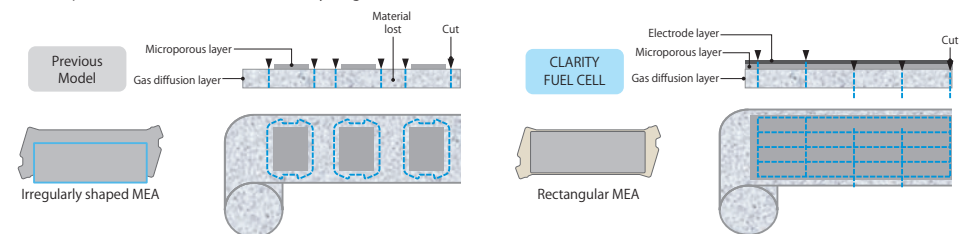

Microporous layers are coated on the gas diffusion layer in a single row with space provided between the adjacent primer layers. This necessitates stamping the MEA shapes, resulting in wasted material.

Because the MEAs are rectangular, microporous layers can be coated continuously on the gas diffusion layers in multiple rows, substantially reducing waste. For the hydrogen electrode, the electrode layers are also coated continuously.

Air Supply System with Electric Turbo Air Compressor and Simple, Compact Hydrogen Supply System

Air (Oxygen) Supply System Adopting Electric Turbo Air Compressor also Contributes to Reduced Fuel Cell Stack Size

To obtain a lot of power from a more compact fuel cell stack, Honda needed to increase the amount of air supply. To achieve this, a new electric turbo air compressor was developed. The design objectives were a high air pressure, high flow rate, and low noise in a lightweight, compact body. The air compressor supplies about 1.7 times higher pressure than the previous model, contributing to improved electricity generation performance of the fuel cell stack.

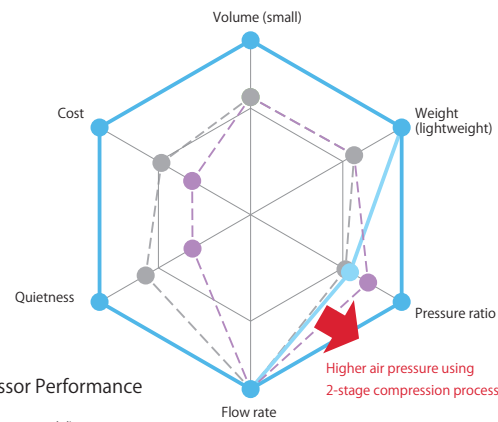

■ Comparison of Air Compressor Performance

- Lysholm (Previous model)
- Roots
- Electric turbo (Clarity Fuel Cell)

● Coaxial 2-stage Air Compression Process Delivers High Pressure in a Compact Body

Two impellers of different shapes share the same axis to provide a 2-stage compression process. The result is a high flow rate and high pressure from a compact body. The adoption of air bearings allows for rotational speeds of up to 100,000 rpm.

■ How the 2-stage Air Compression Process Works

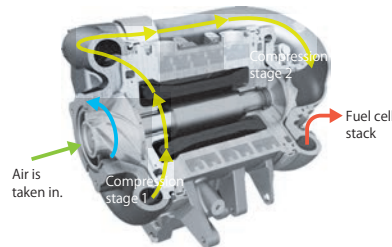

● Low Noise Compressor Makes the System Smaller and Lighter

The electric turbo air compressor produces low sound pressure within a high frequency range that only requires a simple silencer, approximately 60 percent smaller. This combines with a roughly 40 percent smaller compressor body for an overall smaller and lighter air supply system.

Values compared with previous model.

Significantly More Compact and Lighter Hydrogen Supply System With Two Gas Injectors

Hydrogen in the tank, which has been compressed to 10,000 psi (70MPa), is decompressed to approximately 30 psi and supplied to the fuel cell stack. On the previous model, the hydrogen pressure and flow rate were adjusted using a regulator relief valve and ejector. This is replaced by two gas injectors allowing the accurate control of both pressure and flow rate. The result is a roughly 40 percent reduction in the volume of the hydrogen supply system.

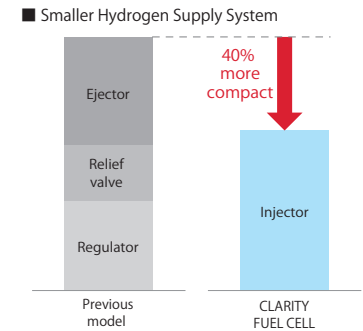

■ Comparison of Hydrogen Supply System Configurations

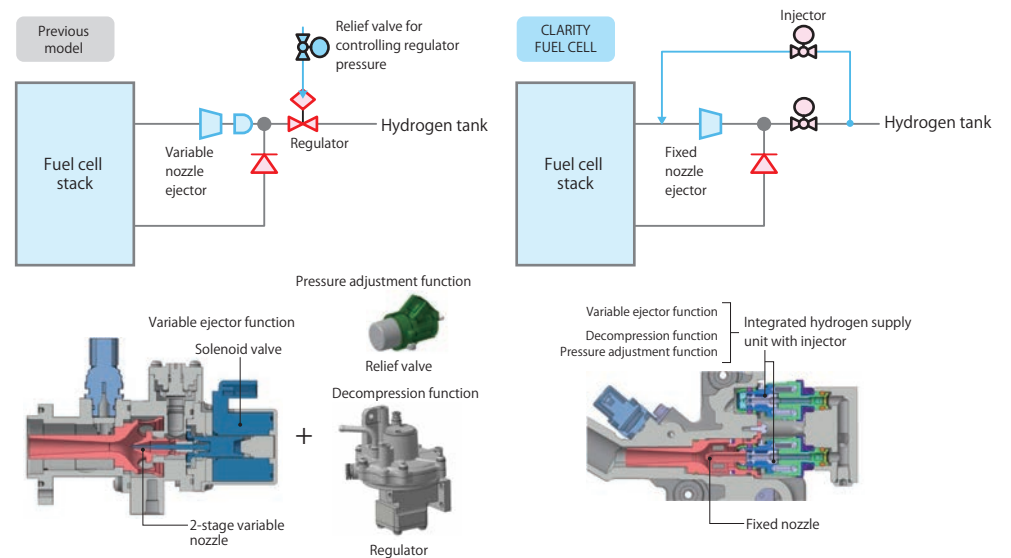

The system consists of: a decompression regulator; a relief valve for adjusting the pressure of the decompression regulator; an ejector with two variable stages to control the recirculation of hydrogen; and a solenoid valve for variable control.

Decompression, pressure adjustment and hydrogen recirculation are all controlled by an injector. No more regulator, relief valve or variable ejector function.

Combining a Voltage Booster to a High Power, Compact Drive Unit For Increased Performance

Newly Developed Fuel Cell Voltage Control Unit (FCVCU) Makes It Easier to Position the Fuel Cell Powertrain Under the Front Hood

On the previous model, the motor was driven at a voltage of up to 330 V from the fuel cell stack and lithium ion battery. On the Clarity Fuel Cell, the newly developed FCVCU boosts this voltage to 500 V max., allowing 30 percent motor output improvement while reducing the number of cells in the fuel cell stack. The motor-PCU has been rotated 90 degrees to bring height down by 34 percent. In the space thus made available, the fuel cell stack now resides. The FCVCU itself adopts a slim design of less than 4-inches thick. Combined, all these changes allowed the engineers to efficiently package the fuel cell powertrain under the front hood.

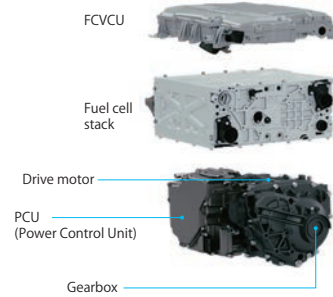

Comparison of Motor Drive Voltages

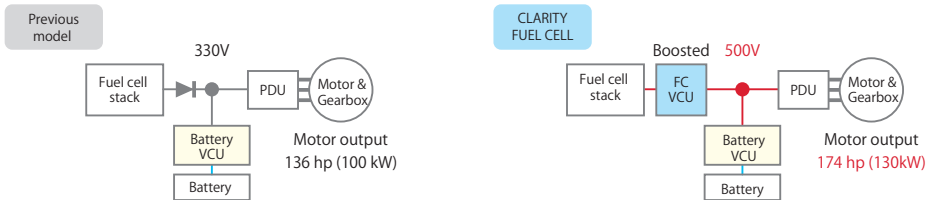

Lower Drive Unit Height

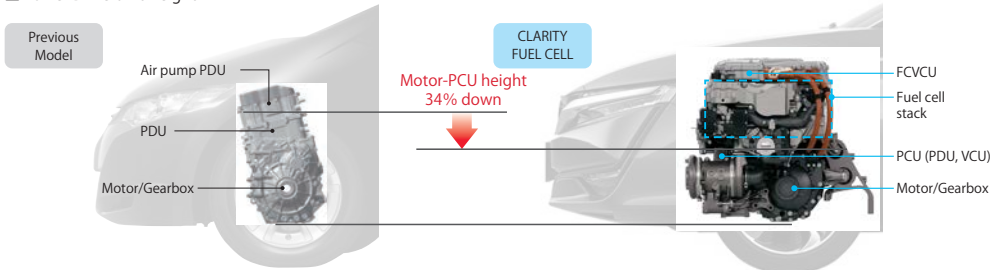

The motor and gearbox assembly is tilted 90 degrees forward, and the integrated PCU comprised of a PDU and battery VCU is placed in front of the motor. The air pump PDU is stored in the center tunnel to provide space for the fuel cell stack and FCVCU.

Smaller, Slimmer FCVCU Designed for Ultimate Performance

This is the world's first FCVCU for a mass-production vehicle that adopts a Silicon Carbide Intelligent Power Module (SiC-IPM), and it also incorporates 4-phase interleaved control and magnetic coupled inductor. As a result, the FCVCU is approximately 40 percent smaller than a comparable unit.

Benefits of Smaller FCVCU

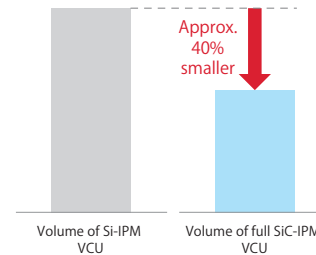
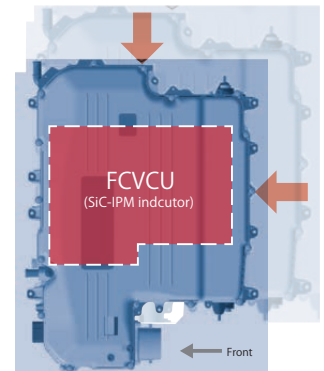

Illustration of FCVCU Size Reduction



World's First SiC-IPM for Mass-production Vehicles

The power semiconductor that controls the system's voltage adopts silicon carbide (SiC) instead of silicon (Si), thus allowing a 4-time higher switching frequency. At higher operating temperatures, silicon carbide offers higher performance with matchingly low heat losses, allowing for a smaller heat sink, and thus more compact overall dimensions.

Smaller Capacitor Made Possible by 4-phase Interleaved Control

The 4-phase drive, based on four SiC-IPM control phases staggered by 90 degrees, minimizes the ripple current by cancelling the current fluctuations generated by switching. This reduces the capacitance requirement for smoothing of ripple current, so a smaller capacitor is used on the primary side.

Magnetic Coupling Inductor is Employed

A magnetic coupling inductor increases voltage as the magnetic density of the coil changes. The integrated inductor, consisting of two inductors placed so that the coils are wound in the opposite direction, cancels out direct-current magnetic fluxes to reduce the ripple current. The design also made the inductor smaller.

Illustration of single vs. 4-phase control

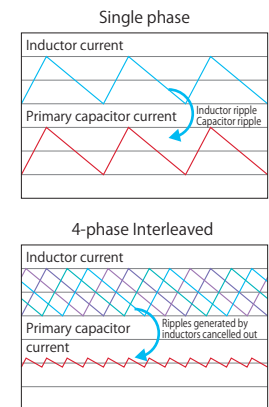

Larger Capacity Battery and Hydrogen Tanks in a Compact, Under-the-Floor Package

Higher-Output Lithium-Ion Battery Neatly Accommodated Beneath the Front Seat

The lightweight, compact lithium-ion battery offers excellent assist at takeoff and during acceleration, along with superb recovery of deceleration energy. The increased output (1.5 times higher than the previous model) is the result of increasing the cell volume by 10 percent and the number of cells by 20 percent. The battery is housed in a sealed case designed so that it can be installed under the floor beneath the front seats to maximize legroom of both the front and rear passengers.

■ Illustration of battery layout

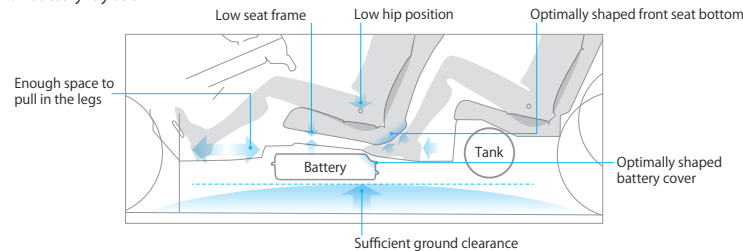

High-pressure Hydrogen Tanks Achieve Higher Packaging Efficiency and Greater Storage Capacity

The Clarity Fuel Cell features the world's first application of aluminum-lined hydrogen tanks meeting the Global Technical Regulation No. 13* and achieve zero hydrogen permeation at a charge pressure of 10,000 psi (70 MPa). In order to maximize overall package efficiency, two tanks of different sizes are used while increasing total hydrogen storage capacity by 39 percent.

■ Comparison of Hydrogen Tank Specifications

	Previous Model	Clarity Fuel Cell
Service pressure	5,000 psi (35 MPa)	10,000 psi (70 MPa)
Hydrogen Capacity	3.92 kg	5.46 kg
Tank Volume	171 liters	141 liters



Design that Protects Against Hydrogen Leaks and High Voltage Currents

The Clarity Fuel Cell was developed to be comparable to a traditional vehicle in all ways, including safety performance. To achieve this, Honda incorporated design considerations to help protect against issues stemming from high pressure hydrogen storage and high-voltage currents generated by the FC and battery pack. To address issues resulting from high pressure hydrogen storage, the first step was to ensure hydrogen does not leak under possible stresses. If a leak does occur, hydrogen sensors at various locations make sure the shut-off valve in the hydrogen tank cuts the hydrogen supply off. In the event of a collision, a signal from the airbag sensor orders the shutting down of the hydrogen supply and the high-voltage circuits. The components that make up the hydrogen system are fully enclosed, and any leaked hydrogen is released away from the vehicle through a duct to the outside.

Honda's principles for Hydrogen safety

- Prevent leaks by design
- Detect & stop leakage should it occur
- Safely releases leaked hydrogen

Hydrogen tank, Fuel cell stack, Hydrogen supply system, Main hydrogen shut-off valve

Fuel cell stack, Hydrogen supply system, Enclosure

Components that make up the hydrogen system are protected & fully enclosed

Hydrogen sensor, Flow of leaked hydrogen, Venting duct

Main hydrogen shut-off valve, Hydrogen supply system, Enclosure, Venting duct

System stopped due to Hydrogen leak
H₂
 Stop the car at a safe place immediately and call your dealer

If hydrogen leakage is detected, the driver is alerted via a warning light in the instrument cluster.

If the hydrogen sensor detects a leak, the hydrogen supply is cut off and the leaked hydrogen is discharged through the venting duct and released through openings in the front fender and fuel filler lid.

* Uniform Global Standards for hydrogen and fuel cell vehicles

Classic Sedan Proportions Incorporating Futuristic Styling Cues

Powerful, Stately Look, Combined with Graceful, Futuristic Beauty

In styling its ultimate clean car, Honda wanted to propose exterior design that represented the dawn of a new era. To satisfy the FCV customer's desire to own a status symbol, the company focused on embodying stately proportions and a futuristic, beautiful sedan form. The graceful one-motion silhouette of the cabin, complete with tinted glass, converges from three directions at the front and rear to express a spacious, bright space that looks and feels like you are inside a glass dome canopy. The low, wide body is accentuated by the 18-inch aluminum wheels and large rear spoiler, adding sportiness to the Clarity. It was the integration of two key themes--stateliness and gracefulness--that signifies this stylish sedan of a new era.

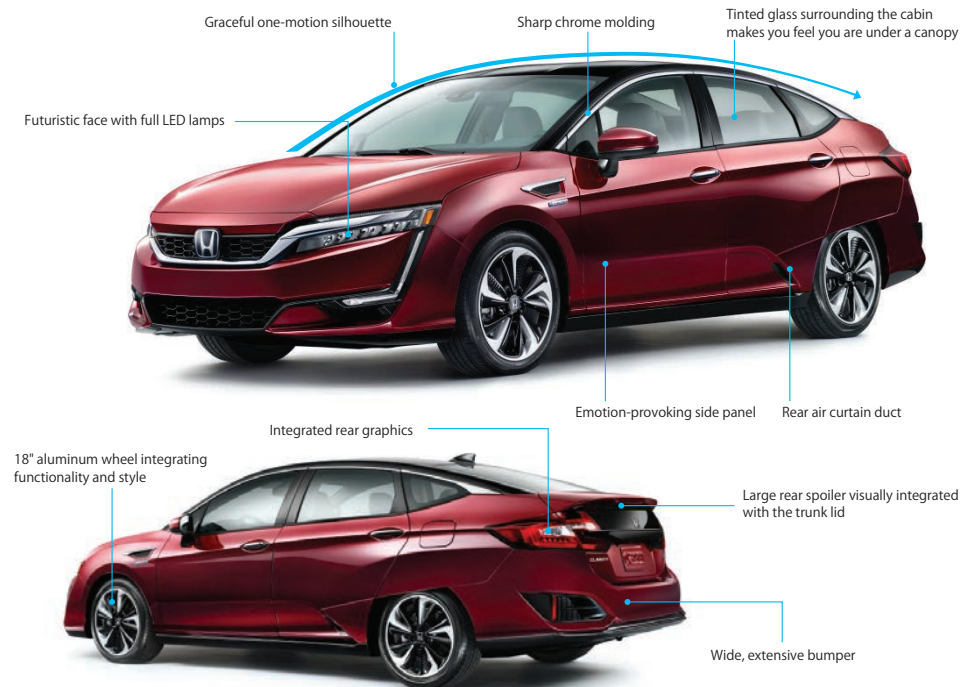

Sharp, Futuristic Full-LED Exterior Lamps

The front of the Clarity is decorated with futuristic full-LED headlights (in-line type), each consisting of nine lamps including three high-beam and six low-beam, with wide L-shaped position lamps/DRL (daytime running lights) generating maximum attention. The linear front turn signal indicator lamps add to the intrepid look. At the rear, the wide signature rear combination lamps evoke emotion as the thick light-conducting lenses of the tail lamps create a sense of intimacy as if a big block of glass was illuminated with indirect light. The rear signal lamps provide deep light emission through the combination of line and surface light emissions.

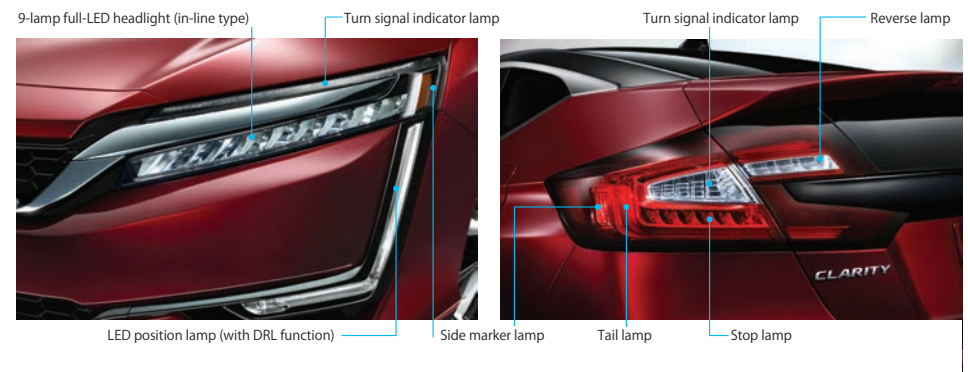

Functional, Stylish 18-inch Aluminum Wheels

The 18-inch aluminum wheels feature spokes that enhance the dynamic look as they rotate and is combined with a lightweight and aerodynamic fin-shaped wheel cap. The plastic cap is lighter, and designed to radiate the heat from the brakes while achieving excellent aerodynamic performance, adding to the long cruising capabilities of the car. The futuristic wheel is a success story of how two different materials can be combined effectively.



Polished Aerodynamic Styling Based on a Traditional Sedan Shape

Aerodynamic, Wide, Beautiful Exterior Style

The aerodynamic goal of the Clarity Fuel Cell was to maximize driving range, without compromising the spacious sedan package or forward-thinking styling. To this end, aerodynamic effect was a key consideration from the initial stages of styling. The idea was to reduce the vertical vortexes of air generated in the rear of the body--a phenomenon specific to sedans. On a typical sedan, the flow of air along the top face of the cabin to the trunk interacts with the flow of air on the side faces of the cabin. Depending on the velocities and directions, large vertical vortexes are generated in the rear of the body which is the main cause of air resistance, ultimately impacting fuel efficiency. With the Clarity Fuel Cell, these vertical vortexes were reduced by optimizing the body shape from the roof to the top of the trunk including the large rear spoiler, as well as the side face of the cabin, without sacrificing interior space. This allowed minimization of the air speed difference between the top and side surfaces of the body. The effort resulted in a graceful exterior styling that demonstrates excellent aerodynamic performance while maintaining a spacious interior.



● Underfloor Covers/Radiator Grille

The underfloor is entirely covered to let the air flow smoothly. The radiator grille has a duct structure inside for efficient cooling of the radiator, which helps minimize the opening area and thereby meet the aerodynamic requirement without compromising on cooling performance.

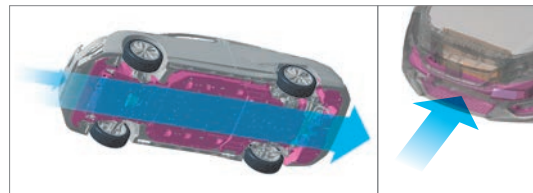

● Front Air Curtain

Air is guided to the front inner fender from under the front bumper to create an air curtain on the outer side of the front tire, eliminating air disturbances along the front tire wheel housing.



Japan market vehicle shown



● Rear Tire Cover

The top of the tire is covered with the body side panel to eliminate air disturbances along the rear tire wheel housing. This helps air flow smoothly to the rear and also contributes to the linear styling of the rear.

● Rear Air Curtain Duct

The Clarity Fuel Cell is the world's first four-door sedan with an air curtain duct below the rear door. Air is guided through the duct rectifying disturbed air along the rear wheel housing to achieve aerodynamic effect. This is another example of an unprecedented marriage of functionality and styling.



● Laser Brazed Roof

The roof side is laser brazed to eliminate the familiar roof molding and thereby reduce the height gap, which increases the seamless look of the roof.

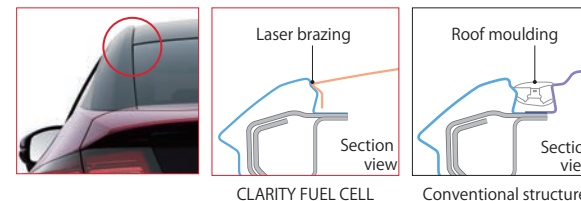

● Rear Combination Washboard

The side face of the tail lamp is stepped to prevent air from going around the side of the lamp and flowing to the rear.



Futuristic Yet Beautiful

New Bordeaux Red Metallic Color

Color design of the Clarity Fuel Cell began with the concept of a clean car with the look and feel of a luxury car, and was further refined by adding stronger gradation to emphasize the beauty of form. Instead of a standard clear top coat, a red tinted clear coat with high chromaticity was adopted to express vivid color and strong gradation. The resulting color is as deep as a gem polished carefully from raw stone.



■ Bordeaux Red Metallic

Structure of paint

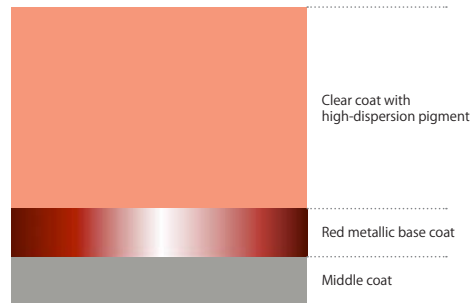
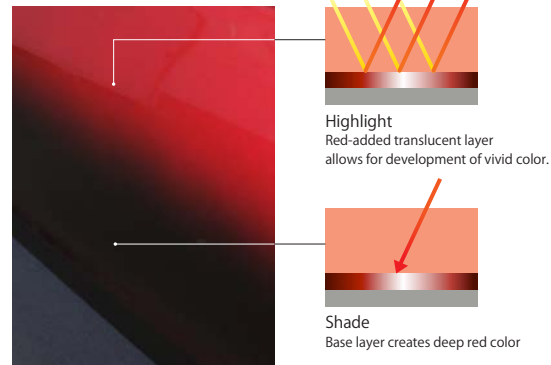

Illustration of Color Development



● Three Choices for Body Color



[Bordeaux Red Metallic]
Gem-like deep but translucent garnet color



[White Orchid Pearl]
Silky pearl white with clear shine



[Crystal Black Pearl]
Complex color combining jet black with pearl finish

Advanced Yet Comfortable

Smart Clear Wiper with Built-in Washer Nozzle for Controlled Spraying

The newly developed wiper adopts an innovative mechanism that significantly improves the washing efficiency of the front windshield to ensure a clear view. The built-in washer nozzle at the supporting base of the wiper arm blade allows washer fluid to be sprayed efficiently near the blade. Furthermore, the spray direction and timing are controlled according to the operating direction of the wiper. As the washer fluid is wiped off immediately after spraying, the view is never obstructed by the washer fluid. What's more, how much the washer fluid will be sprayed is controlled according to the ambient temperature and vehicle speed, which achieves excellent washing efficiency while realizing water savings of approximately 50 percent.

■ Smart Clear Wiper



The built-in washer nozzle allows for efficient spraying of washer fluid near the wiper blade.

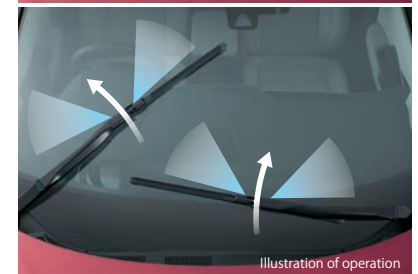
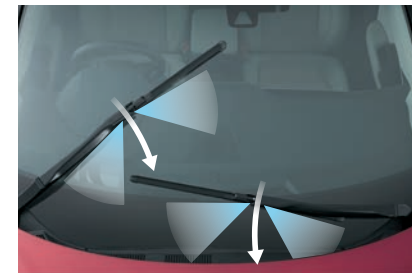

Washer fluid is sprayed only to the moving direction of the wiper.

Relaxing Interior You Won't Want to Leave

Inviting Cozy Space

To make traveling in the Clarity Fuel Cell an even more comfortable experience, Honda created a space where occupants can unwind and relax. The horizontal line that extends linearly and firmly from the center of the instrument panel to the right and left doors is the basis of the wide interior that feels more spacious than its dimensions. Furthermore, areas that are frequently touched and seen are carefully finished using materials that look inviting and feel soft and comfortable.



- Instrument and Door Panel Pad Made of Ultrasuede®

The middle pad of the instrument panel and door trim adopt Ultrasuede® made of recycled polyester yarn. The quality material covers wide areas of the interior and envelops its occupants in comfort.

- Warm Black Woodgrain Panel

The generous decorative panel features dynamic rosewood grains throughout. The surface has an irregular finish corresponding to grain patterns to create the warmth of wood.

- High Quality Seats

The seats use firm genuine leather for the center, and soft Prime Smooth for the sides. Elaborate upholstery and stitching of the two materials speak volumes about the quality of the seat construction and attention to detail.



Welcoming, User-Friendly Comfort Features

The fuel cell stack, which was built into the center console on the previous model, is stored under the front hood to achieve significant space savings. The high-deck console of the Clarity Fuel Cell makes effective use of the resulting space below. The compact switch-type shift-by-wire control leaves large utility space under the console for easier access and operation. Other welcoming rear seat features like A/C vents, 12-volt power outlet and smartphone pockets in both front seat backs help make the interior of the Clarity a pleasant and inviting space for passengers.

The console tray is visible and easily accessible seated



Console box

Console tray

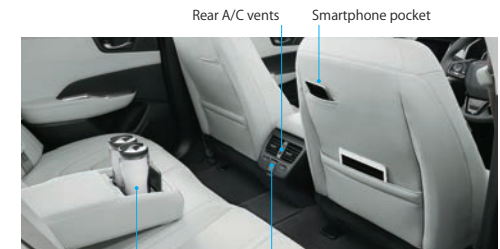

Rear A/C vents

Smartphone pocket

Armrest with cup holders

12-volt Power outlet

Simple, Modern Interior

Designers chose interior colors to help accentuate the simple form and texture of materials in the Clarity Fuel Cell. The options include a clean, attractive platinum gray and a chic, luxurious black. Both mono-tone color schemes create a sophisticated, tranquil space.



Interior color: Platinum Gray



Interior color: Black

Information Display Function That Excites the Driver

Digital Graphic Meters Intuitively Communicate How the FCV Is Driving

The graphical LCD meter panel with silver-frame zoning lets the driver instantly recognize various information, providing a human-machine interface that allows for intuitive operation. The speed indicator, fuel cell generation monitor and power/charge meter are graphically rendered at the center of the LCD. At the left and right of the meter panel are the high-voltage battery meter and fuel meter. The clear zoning allows information to be recognized instantly while driving. The driver can switch between the audio, navigation and other information screens using the steering-wheel mounted switches.

● Fuel Cell Generation Monitor

The monitor visually informs the driver of the generation level of the fuel cell. The size of the ball at the center changes according to the generation level.

● Power/Charge Meter

The drive output and regenerative power of the motor are shown along the arc. For the drive output, the power source currently used for driving—high voltage battery only, high-voltage battery + hydrogen, or hydrogen only—is indicated by the needle that clearly shows the constantly changing source of power.

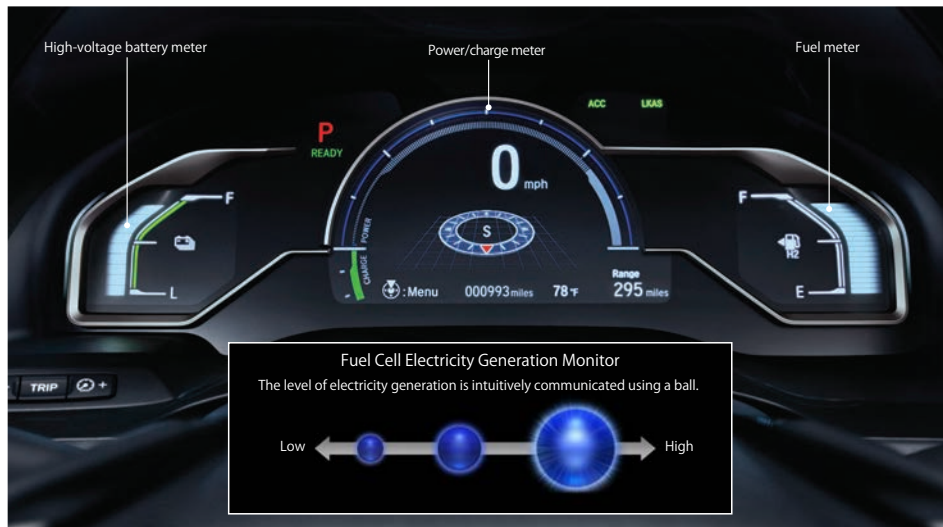

HondaLink® with Hands-free Smartphone Link

The 8-inch high-definition, wide-angle electrostatic touch-panel display is easy to see and supports Apple CarPlay™ and Android Auto™ allowing for compatible smartphones connected via a USB cable to be displayed and operated more securely and easily. The driver can also make calls from the address book displayed on the meter panel, change the audio source and select preset channels using the steering-wheel mounted switches. Moreover, the HondaLink® function allows the driver to get hydrogen station location and operating information. The energy management screen shows the hydrogen usage in real time.



Head-up Display with Useful Driving Information Projected on the Front Windshield

The head-up display projects information on the front windshield to reduce eye movements of the driver. Useful information such as road signs, current speed limit and route guidance are projected in a simple, easy-to-understand manner. The display brightness is automatically adjusted according to ambient light, and the display position can be adjusted as desired.



■ The meters were lit up to be captured better in the photograph ■ The screen images are simulated

Safety/Comfort FCV Functions Connecting the Man and Machine

Advanced Functions Developed under the Concept of "Connected E-machine"

The Clarity Fuel Cell provides advanced functions that connect the car to its users whether near or far from the car. Simply download the HondaLink® app to your smartphone, and you can connect to your Clarity Fuel Cell securely and comfortably.

● HondaLink FCV Telematics App to Connect to the Car Remotely

The "Connect to Car" feature of the HondaLink app lets the owner display the remaining hydrogen level, drivable distance, drivable days and other vehicle information on a smartphone. With the app, the A/C can be turned on/off or set up to turn on at a specified time.

Remote Communication - FCV Telematics

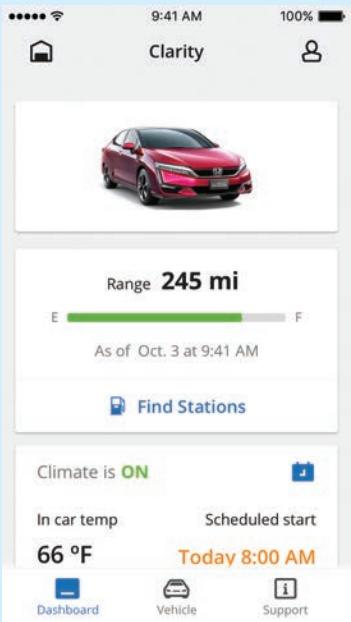
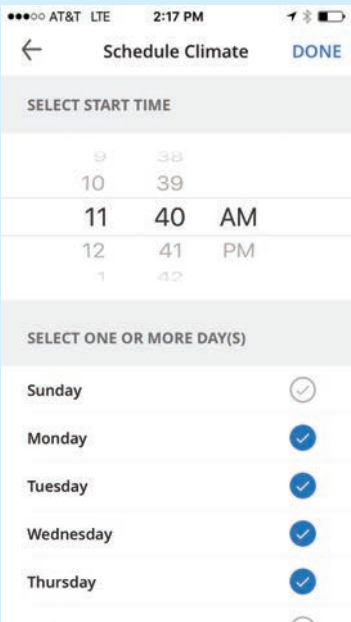
<p>Secure</p>	<p>Use a smartphone to check the remaining hydrogen level, cabin temperature, range, and more from home, office or other locations away from the car.</p> 	<p>Comfortable</p>	<p>Use a smartphone to turn on/off the A/C from home, office or other location away from the car. The driver can even set a timer beforehand to make the A/C turn on automatically before the trip.</p> 
---------------	---	--------------------	--

Comfortable Space Designed with Consideration to Passenger Well-Being & Environmental Responsibility

Total Air Quality Management Keeps Cabin Air Cleaner Than the Outside

The Clarity Fuel Cell adopts a number of technologies to improve air quality under the concept of Total Air Quality Management, where the goal is not only to consider the environment but also to support the comfort and well-being of users while traveling in the car.

- Climate Control (Air Quality Sensor)

The air quality sensor detects NO_x, CO₂ and other harmful substances in the outside air and if necessary, the system automatically switches to the internal recirculation mode to prevent harmful gas from entering the cabin.

- A/C Filter (Allergen-free High-performance Deodorizing Filter)

The air conditioning system filter has a deodorizing function designed to prevent the smell of exhaust gas, while the anti-allergic agent permeated into the filter helps keep allergen activity under control.

- Instrument Panel (Plasma Cluster® Technology)

Whenever the climate control fan is on, ions are generated (by the ion generator located within the IP) to break down/eliminate the bacteria suspended in air, to prevent bacterial growth and eliminate odor. The dedicated round-shaped, silver ringed air outlet located between the two air outlets above the navigation system display screen.

- Floor Mat/Area Around Battery Cooling Vent (TRIPLE FRESH®)

The functional fiber adsorbs and breaks down formaldehydes and other sources smell such as pets or cigarettes.

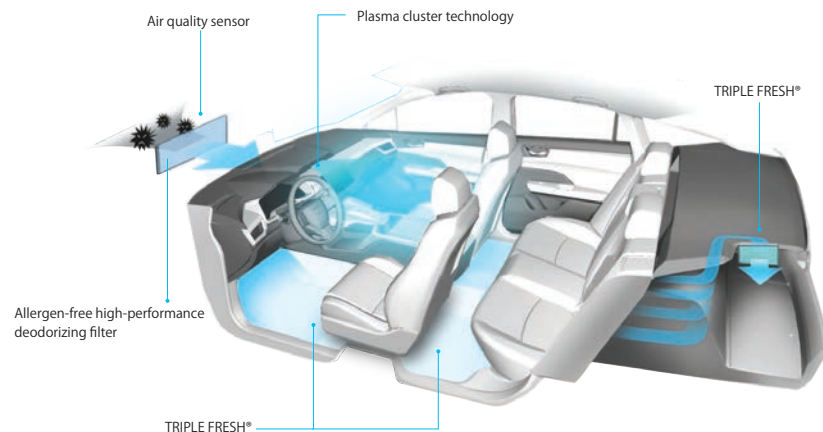

Energy-saving A/C System Utilizes Exhaust Heat from the Fuel Cell System

On the previous model, cabin heating depended solely on a water heater that generated warm air by heating water with electricity. For the Clarity Fuel Cell, a new FCV A/C system was developed that utilizes exhaust heat from the fuel cell system. When the fuel cell stack is cold, warm water is supplied to the A/C from the water heater as before; however, once the fuel cell stack reaches operating temperature, warm water is supplied to the A/C from the fuel cell stack. This provides a cold weather energy savings of approximately 20 percent.

Environmentally Responsible Materials Cover Nearly 80 Percent of Interior Surfaces

Honda worked to further reduce carbon emissions by adopting plant-derived green materials, recycled materials, and aluminum dies for the Clarity interior. All plant-based materials are made of oils extracted from non-edible parts of plants, so as not to affect food supply. Prime Smooth® linings on the sides of the seat cover are made with bio-fibers. The genuine leather used in the main area of the seats has been confirmed to originate from cows used for food.



- Plant-derived Material

Prime Smooth® used for the roof lining and sunvisor, and also for the linings of synthetic leathers covering the seat and armrest, is woven with fibers that are made of oils extracted from non-edible materials.

- Recycled Material

Ultrasuede®, the soft pad cover material used for the instrument panel and front/rear door linings, is made of recycled polyester yarn.

- Low-carbon Parts Manufacturing

Aluminum dies are used to make the rear tray, pillar garnishes, etc., in order to reduce the power consumption from metal processing and thereby reduce CO₂ emissions in the manufacturing process.

Exhilarating Driving Feel with Direct Acceleration Response

Linear, Powerful and Quiet Acceleration that Redefines the Meaning of Luxury

The exhilarating driving experience expected from a motor-drive mechanism was taken to the next level. The Clarity Fuel Cell's motor, which boasts higher output, produces maximum torque right from the start and accelerates the car powerfully and smoothly without needing to shift. Although full-throttle acceleration performance of the Clarity Fuel Cell is similar to that of a mid-size* sedan, immediate response to accelerator inputs and the corresponding feeling of acceleration reaches beyond the realm of internal combustion engine-powered vehicles in day-to-day driving situations.

* Naturally aspirated engine with a displacement of 2.0 to 3.0 L



Full Throttle Acceleration Performance

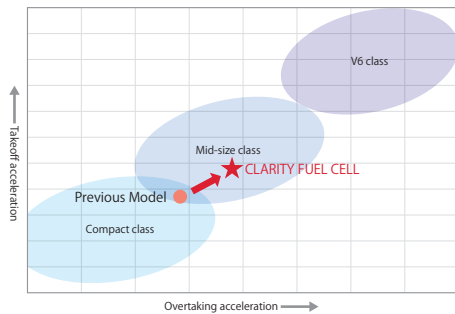

Overtaking Accel G Characteristics (Accelerator at 50 percent)

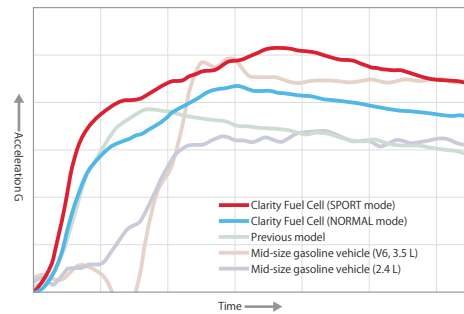

SPORT Mode for More Direct, Responsive Driving

The newly adopted mode selector switch creates two different driving experiences: NORMAL mode emphasizes ease of handling in day-to-day driving, while SPORT mode makes the motor respond quicker to accelerator pedal operation to create a direct acceleration feel. In SPORT mode, motor regeneration response is also quicker when the accelerator pedal is released to affect the engine braking and to let the driver enjoy a sportier driving experience.

Evolutionary Drive Motor Achieves Higher Output, Higher Torque and Higher Rotational Speed

As the new FCVCU increased the maximum drive voltage of the motor from 330 V to 500 V and increased the stator stack size by 10 percent, the maximum motor output increased 30 percent to 174 hp (130 kW), while maximum torque increased 17 percent to 221 lb-ft (300 N·m).

Comparison of Performance Curves

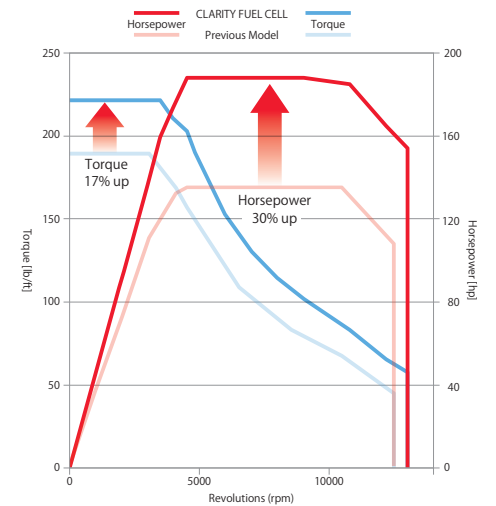

Comparison of Motor Specifications

	Previous model	CLARITY FUEL CELL
Maximum power	134 hp	174 hp
Maximum torque	189 lb-ft	221 lb-ft
Maximum revs	12,500 rpm	13,000 rpm
Maximum speed	99 mph	103 mph

Reduced Motor Noise

The motor housing has additional ribs to increase rigidity, and the skewed rotor is split in four instead of two to reduce torque fluctuations. The stator is also set up to reduce vibration, making the motor quieter while producing higher output and motor speed. The result is a truly quiet, ultra-smooth driving experience.

Motor Noise Reduction Factors

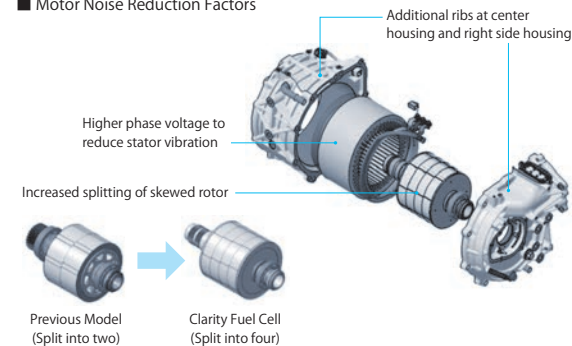

Effects of Noise Reduction

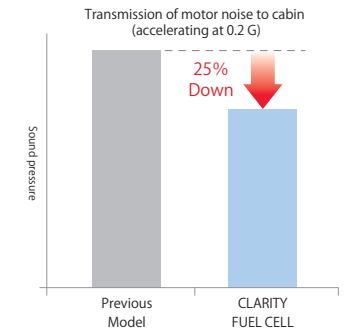

Longest Driving Range Rating of Any Zero-Emission Vehicle Makes Clarity Viable for Everyday Use

366 Mile Range Achieved by Intelligent Energy Management and Lower Road Load

Honda wanted to improve the fuel efficiency of the Clarity Fuel Cell to make it easy to use in everyday situations like running errands but also driving long distance. By making the fuel cell powertrain more efficient and implementing intelligent energy management, while also minimizing road load (running resistance), Honda was able to reduce hydrogen consumption. Combined with an increase in the amount of hydrogen the car can carry, this helped push the driving distance per hydrogen charge dramatically higher—to an EPA range rating of 366 miles*¹, up 58 percent over the previous model.

● Energy Management Maximizes Electricity Generation Efficiency

The amount of electricity the motor needs varies depending on the driving condition. If the electricity required by the motor is outside the efficient operating range of the fuel cell, fuel efficiency will be reduced. That is why Honda developed intelligent energy management control logic to keep the fuel cell in the operating range associated with the best generation efficiency. How the vehicle will be driven is predicted (using past data on driving patterns) and if the predicted pattern indicates that the battery will likely be charged by regenerated energy, the electricity stored in the battery is actively used. This prevents inefficient generation fluctuations of the fuel cell stack and improves the fuel efficiency even in driving situations where the vehicle accelerates and decelerates repeatedly.

■ Illustration of How Energy Management Works

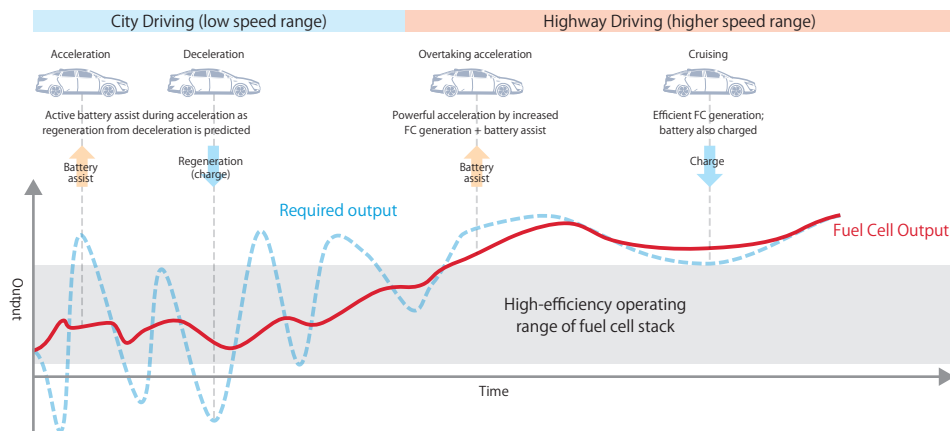

● Minimized Road Load (running resistance)

In an effort to improve the aerodynamic performance of the Clarity Fuel Cell, Honda engineers began at the initial stages of exterior styling, resulting in an 8 percent reduction of the CD value compared to the previous model. Other improvements include the 235-mm tire with low rolling resistance despite its width, and a brake caliper designed to produce substantially lower running resistance. These are only a few examples of how careful engineering achieved dramatically lower road load.

■ Illustration of Lower Running Resistance

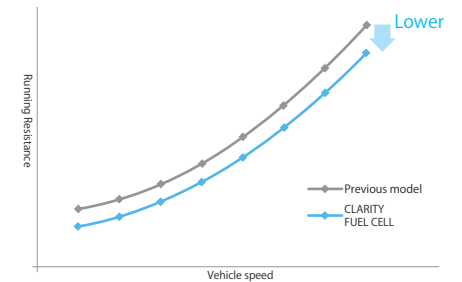

■ Factors of Lower Running Resistance

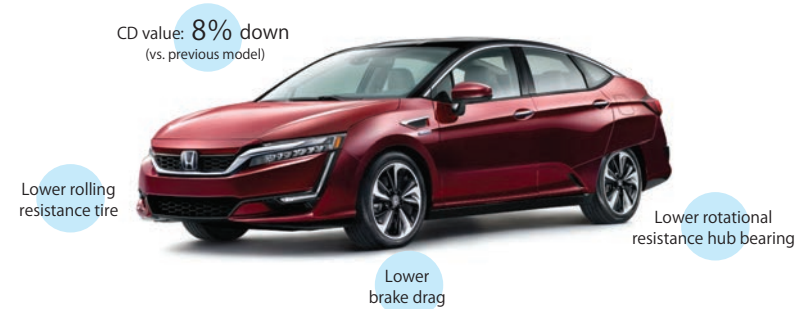

Similar to Gasoline Refueling, Hydrogen “Charging” Takes Less Than Five Minutes

The Clarity Fuel Cell meets the charge standard of 10,000 psi (70 MPa). One hydrogen charge takes only about three to five minutes*², which makes the Clarity Fuel Cell as easy to refuel as any traditional gasoline vehicle.



*1 Based on 2017 EPA Ratings. Use for comparison purpose only. Your range will vary based on how you drive and maintain your vehicle, driving condition, powertrain condition, and other factors. The driving distance varies considerably depending on the use environment (such as weather and traffic level) and driving method (such as quick takeoff and use of A/C).
 *2 Measured by Honda charging from a station at a hydrogen charge pressure of 70 MPa based on the standard condition specified by the SAE standard (J2601). The charge time varies depending on the hydrogen charge pressure and ambient temperature.

Lightweight, Low Center of Gravity Chassis Gives Supple, Direct Driving Feel

Smooth, Flat, Stable Ride Facilitated by Low Center of Gravity and Lightweight Suspension

Carrying the hydrogen tanks, battery and other heavy items low in the vehicle, the Clarity Fuel Cell has a center of gravity approximately four inches lower than the Accord Hybrid. Combined with the low-roll, lightweight, low-friction suspension and amplitude-adaptive dampers, this helps the Clarity offer a smooth and flat ride. Honda also adopted a rear suspension boasting high alignment rigidity, dual-pinion assist EPS creating an excellent steering feel, and a precision-control electric servo braking system. These elements combine to endow the Clarity Fuel Cell with direct handling and supple ride comparable to, or better than, a conventional premium sedan.

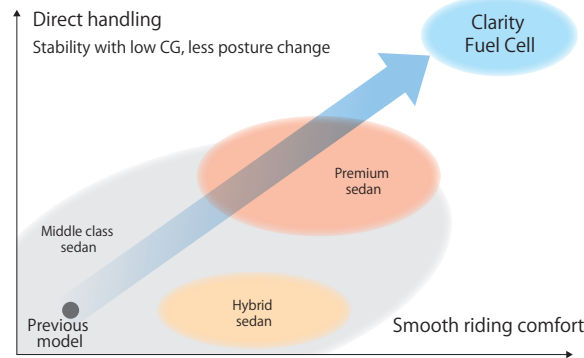

● Exceptional Ride Comfort and Steering Stability via Reduction of Suspension Unsprung Mass

The front strut suspension is structurally lighter than other types of suspension to begin with, while the forged aluminum lower arm is 30 percent lighter than a conventional steel-pressed arm, and the hollow knuckle is 10 percent lighter than conventional solid knuckles. All of the arms of the rear multi-link suspension are forged aluminum instead of steel as on the previous model, to achieve a 40 percent weight reduction. The tie-rod, manufactured by the world's first high-strength aluminum forging method, is 20 percent lighter than a conventional aluminum-forged type.

■ Front Suspension

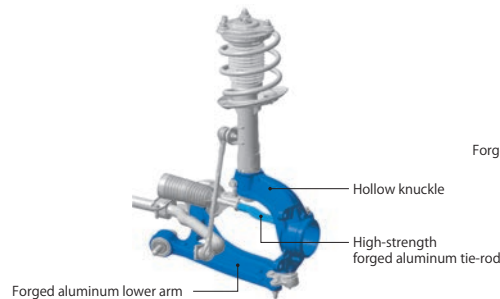

■ Rear Suspension

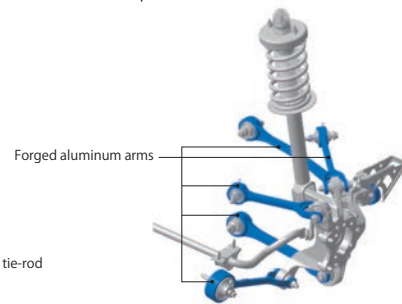

● World's First Hollow Die-cast Aluminum Front Subframe for Automobiles

The subframe of the Clarity Fuel Cell is die-cast from aluminum as one piece with a hollow interior, instead of the traditional welding together multiple members, to achieve a substantial weight saving of 20 percent versus conventional manufacturing methods. The result is one of the world's lightest aluminum subframes. The innovative aluminum die-casting method draws on technologies Honda has built through its experience with motorcycles which creates a seamless structure with hollow, closed sections that allows for thickness reduction. Since no welding flange is required, the resulting subframe is very rigid and light.

■ Front Subframe

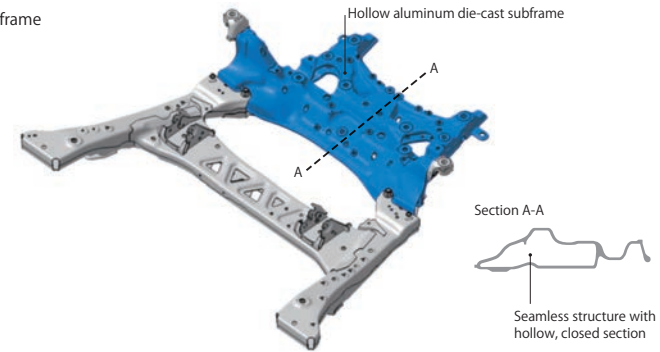

● Lightweight, High-Rigidity Rear Subframe with Hydrogen Tank Retention Structures

The new high-rigidity aluminum rear subframe was developed to carry the heavy hydrogen tanks at positions closer to the longitudinal center of the vehicle and also to withstand the higher suspension inputs given the heavier vehicle. The squeeze-cast subframe is 27 percent lighter than the rear subframe on the previous model, while ensuring high rigidity and strength. Also, the rear beam is bent to hold the hydrogen tanks at low positions, which helps increase the trunk volume and lower the center of gravity. Stability is improved significantly by the rigid stiffeners that double as hydrogen tank protectors.

■ Rear Subframe

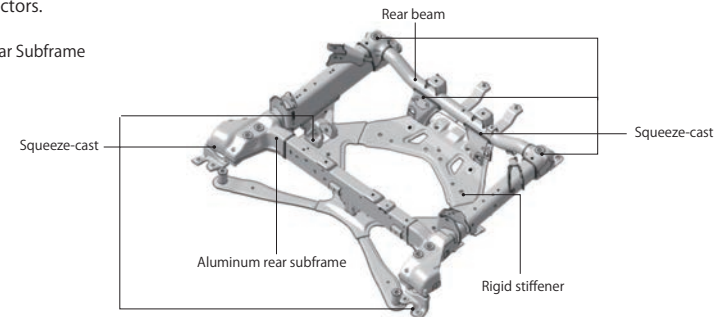

Next-Generation Body Features Advanced Lightweight Materials, Achieving High Standards for Comfort, Driving and Safety Performance

Substantially Lighter, but More Rigid and Stronger Exterior Aluminum Parts

With the Clarity Fuel Cell, Honda worked to reduce the weight of the body structure while also achieving exhilarating driving feel, long driving range, high interior comfort and superior crash safety performance, among others. To accomplish these goals, super-high-tensile materials (980-MPa and 1500-MPa class) were used for approximately 40 percent of the platform in addition to lightweight aluminum exterior parts and advanced composite materials. Thanks to these efforts, Clarity has a next-generation steel body that absorbs more impact, yet is approximately 15 percent lighter than a traditional mid-size sedan. Also, a more rigid body leads to greater handling stability.

Locations of Lightweight Materials Usage

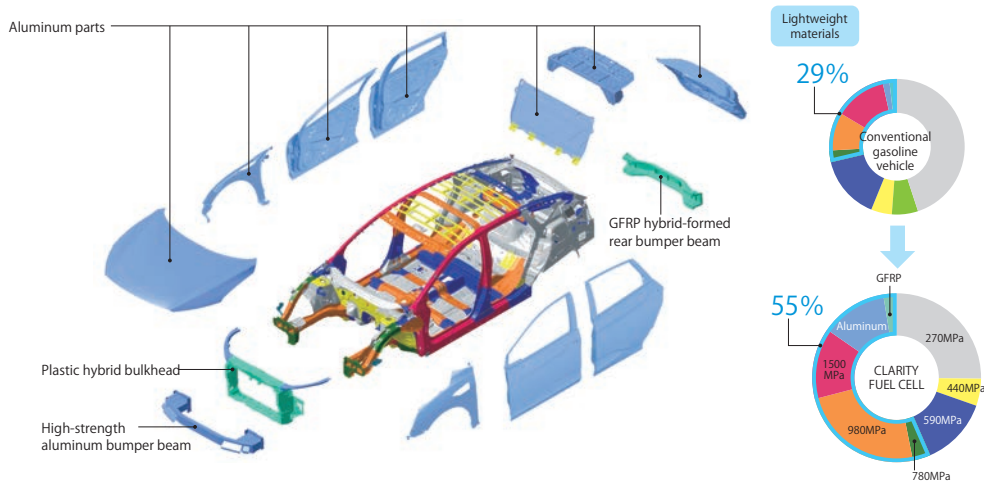

World's First GFRP Hybrid-formed Rear Bumper Beam

Honda developed a new rear bumper beam using Glass Fiber Reinforced Plastics (GFRP) which is lighter yet still able to withstand the crash loads under various conditions at low to high speeds. Made by hybrid forming, using layered discontinuous glass fibers and continuous glass fibers, the bumper beam boasts higher molding efficiency, is extremely lightweight, and achieves high structural strength.

Plastic Hybrid Bulkhead

The front bulkhead is made of plastic, instead of commonly chosen steel, while the front bulkhead upper welded to the body is made of aluminum. This structure is an efficient way to ensure rigidity and reduce weight.

Extensive Use of High-λ 980-MPa Class High-tensile Material

Traditional 980-MPa class high-tensile materials were difficult to form and thus used only for members of simple section shapes such as front pillar stiffeners. The Clarity Fuel Cell is the world's first use of high-λ 980-MPa class high-tensile materials --advanced materials offering excellent formability-- for automotive parts. The car also expanded the application of 1500-MPa class hot stamped materials. Extensive use of these super-high-tensile materials is the key to the efficient sedan packaging, superior safety performance, and substantial weight reduction.

Application of Super-high-tensile Materials

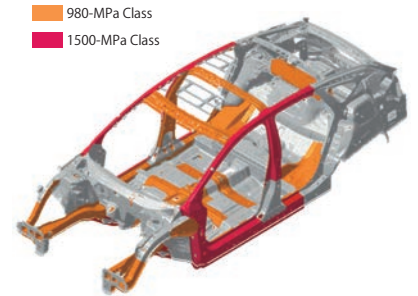

Extensive Use of Aluminum for Interior and Exterior Parts

A number of exterior parts, including the front hood, fenders, doors and trunk lid, are made of aluminum. By adopting aluminum for the sash and many interior parts, the doors were made substantially lighter. Aluminum is also used for the rear parcel shelf separating the trunk and cabin, and for the rear bulkhead. The front bumper beam and door beam use 7000-series high-strength aluminum alloys.

Excellent Sound Insulation for a Peaceful Driving Experience

As a fuel cell vehicle, the Clarity is inherently quieter than other vehicles as it has no pistons or other reciprocating parts to produce vibration and no combustion noise. However, Honda engineers took quietness to the next level by effective use of sound-absorbing and sound-insulating materials, while also adopting acoustic glass for the front windshield and doors*.

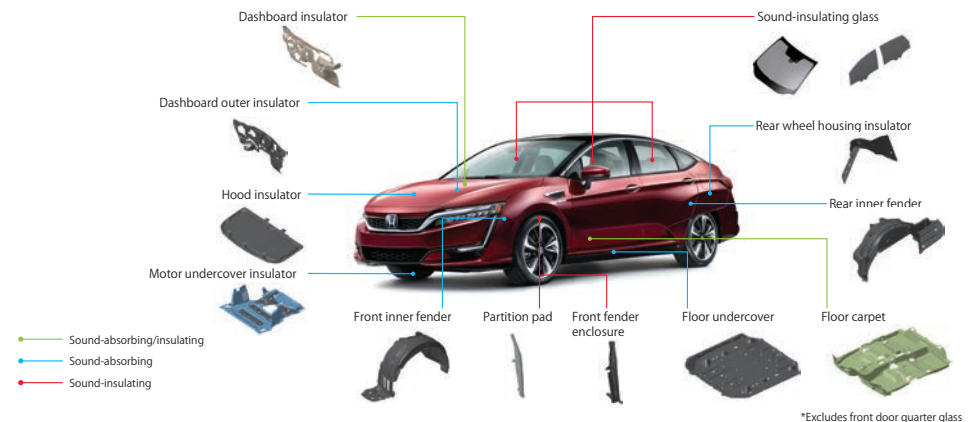

Crash Safety Based on a Dedicated Electrified Vehicle Platform

Straight-Frame Platform to Accommodate FCV Components

A key to the Clarity development was a dedicated platform able to protect the battery, hydrogen tanks and other components not found in a traditional gas-engine vehicle, while absorbing crash energy efficiently. Specifically, a subframe was developed that can also be used as a crashworthy structure in the rear, and connect the front side frame, front subframe, main frame, rear subframe and rear side frame along a straight line. The resulting structure effectively absorbs crash energy applied from the front and rear, with the battery robustly protected by the strong main frame. The hydrogen tanks are constructed in such a way that, in the event of rear-end crash, they are protected by the rear subframe, while load-path structure in which loads from crash energy are dispersed to the main frame. With the powertrain installed in the front and the battery at the center of the body, the straight layout allows the Clarity platform to be uniquely adapted to multiple electrified vehicles.

■ Straight-frame platform

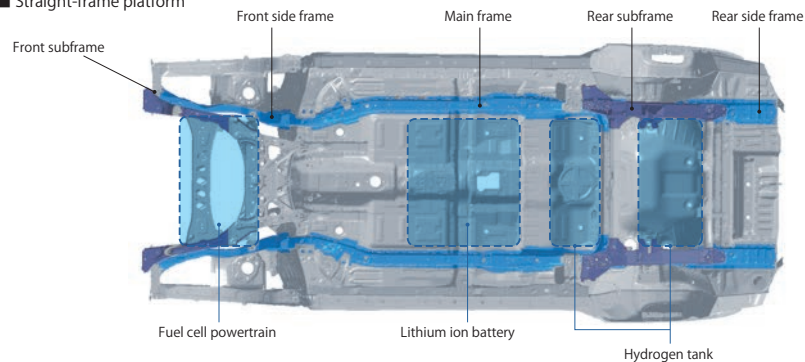

■ Crash Tests



Frontal offset barrier crash

Rear-end crash

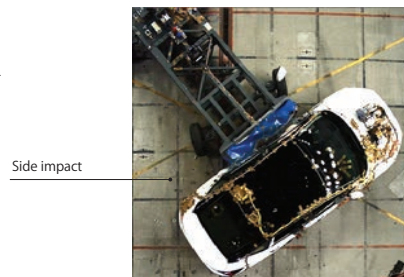

Side impact

Structural Load Paths for Dispersing Crash Load and Efficiently Absorbing Energy

The Clarity Fuel Cell is designed with structural load paths that efficiently disperse crash load in the event of frontal crash, side impact or rear-end crash. Particularly in the case of frontal and rear-end crashes, the subframes are actively used as load paths.

● Frontal Crash Load Paths

Not only the front side frame and upper member but also the front subframe is used to effectively disperse crash energy. In addition, the linkage bracket located at the rear edge of the front subframe deforms to let the steering gearbox and other components, slide back in a downward slope, to protect the cabin in the event of frontal crash.

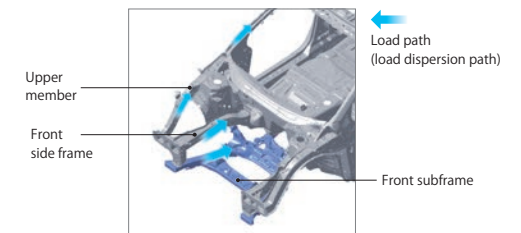

● Side Impact Load Paths

The center pillar, floor cross-member and roof cross-member form a strong circular structure that effectively disperses and absorbs crash energy.

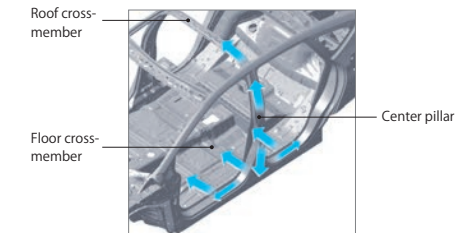

● Rear-end Crash Load Paths

The impact absorbing member provided at the rear edge of the rear subframe is effectively crushed to absorb crash energy with a limited stroke.

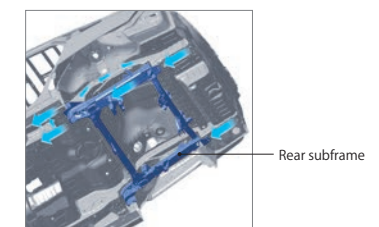

Driving Assist Functions and Key Safety Features

- Honda Sensing™
- LaneWatch
- Agile Handling Assist
- Motion Adaptive EPS
- Emergency Stop Signal
- Proximity Warning System
- Drive and Passenger-side i-SRS
- Front i-side Airbag System + Side Curtain Airbag System (Covering Front/Rear Seats)
- Driver-side SRS Knee Airbag System, Etc.

Honda Sensing™ -- Advanced Driver Assistive Technologies on the Road Towards a "Collision-Free Society"

Honda Sensing Assists Secure, Comfortable Driving

Under the global slogan of "Safety for Everyone," Honda aims to achieve an "Collision-free Society" that promises safe living for every road user. Based on this philosophy, Honda has developed technologies to prevent collisions, crash safety measures to provide protection should a collision occur, and pre-crash safety measures to reduce the damage from a collision if it cannot be avoided. Drawing on the wealth of technologies to detect the outside world that Honda has built in pursuit of safety, Honda Sensing driver assistive technologies are designed to support secure, comfortable driving and are standard on the Clarity Fuel Cell.

● Millimeter-wave Radar and Monocular Camera Support Accurate Detection for Secure, Comfortable Driving

This system is comprised of a millimeter-wave radar in the front grille and a monocular camera inside the front windshield glass. The millimeter-wave radar can detect the position and speed not only of a distant target, but also of a pedestrian that does not reflect waves efficiently. The monocular camera can identify the attributes and size of a target as far away as 200 feet forward of the vehicle. Accurate detection functions realized by a combination of these two devices are cooperatively controlled with the brake, steering and other components of the vehicle to provide comprehensive driving assist.

■ System Configuration



[Adaptive Cruise Control (ACC) with Low Speed Follow]

The millimeter-wave radar and monocular camera are used to determine the distance and speed difference from the vehicle detected ahead, and the accelerator and brake pedals are controlled to keep the set following interval. In moderate traffic on freeways, etc., the system can automatically stop the vehicle to reduce the driver's load.

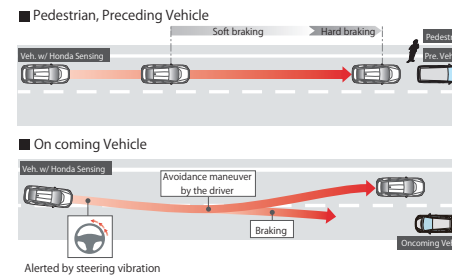
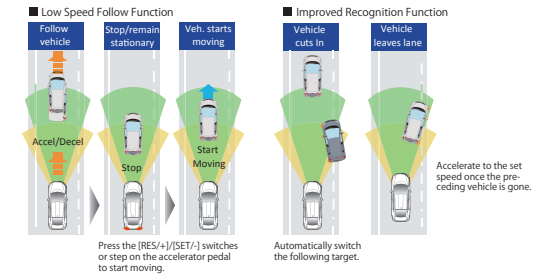

[Collision Mitigation Braking System (CMBS)]

The millimeter-wave radar and monocular camera are used to detect a preceding vehicle, oncoming vehicle or pedestrian. If a potential collision with a detected object is determined, the system alerts the driver with a visual or audible warning. In an emergency, the brakes are actuated to avoid collision or

[Lane Keeping Assist System (LKAS)]

The monocular camera is used to detect the driving lane. On freeways, etc., steering operations are assisted to keep the vehicle inside the lane to reduce the driver's load. If the vehicle gets too close to the line on either side of the lane while the LKAS control is active, the steering wheel vibrates to alert the driver.

LKAS actuates only when the vehicle is driving at 40 mph or above.

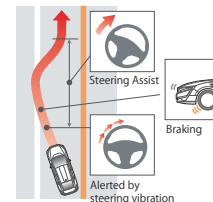

[Road Departure Mitigation]

The monocular camera is used to detect the driving lane. If the vehicle gets too close to the line on either side of the lane, the steering wheel vibrates and a visual warning is issued, and also the steering wheel is controlled to help keep the vehicle inside the lane. If it is predicted that the vehicle has moved excessively to either side, brakes are controlled to help prevent the vehicle from departing from the roadway.

Lane departure may not be prevented depending on the driving condition, road surface condition, etc.

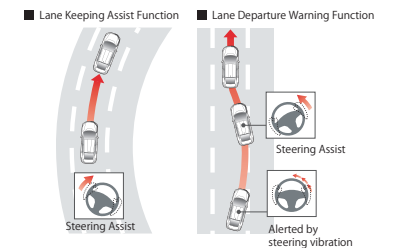

Moving Toward a Hydrogen Society

On the way to realizing “the Joy and Freedom of Mobility” and “a Sustainable Society where People Can Enjoy Life” Honda has been actively developing fuel cell vehicles.

At the same time, Honda has developed hydrogen stations capable of efficiently and cleanly extracting hydrogen using renewable sources of energy, thus creating a link between the fuel cell vehicle using hydrogen energy and the station providing it.

One outcome of this R&D is the Smart Hydrogen Station (SHS), an easy-to-install package that allows for production of energy where it is consumed.

Honda has also developed portable external power export devices and chargers--technologies to connect hydrogen to society by transporting the electricity generated by FCVs to homes, public facilities and even disaster-hit communities.

Our goal is to make these technologies that Produce, Use and Connect hydrogen more accessible to better the lives of people and our society at large.

Honda is committed to advancing hydrogen technologies further to make FCVs a true alternative to gasoline vehicles, combining these technologies to connect people, social infrastructure and cars in new, innovative ways.



* Not currently available in the U.S. market.

Progress of Honda Fuel Cell Vehicles

1999

Sept Honda unveiled the test vehicles "FCX-V1" (pure hydrogen type) and "FCX-V2" (methanol reforming type) carrying fuel cells.



FCX-V1



FCX-V2

2000

Sept Honda unveiled the test fuel cell vehicle "FCX-V3" (high-pressure hydrogen type, with ultra capacitor).



FCX-V3

2001

July Honda started public road testing of its FCX-V3 in Japan.

July Honda started trial operation of a hydrogen production/supply station on the premises of Honda R&D Americas (California).

Sept Honda unveiled the prototype fuel cell vehicle "FCX-V4" boasting longer cruising distance.



FCX-V4

2002

Mar Honda FCX-V4 was approved by the Ministry of Land, Infrastructure, Transport and Tourism.

July Honda became the world's first automaker approved by the U.S. government to sell fuel cell vehicles, planning to start sale by the end of the year.

Oct Honda enters a basic agreement with the City of Los Angeles to sell fuel cell vehicles to the city, becoming the first automaker to enter into a fuel cell vehicle sales agreement with a municipality.

Nov Honda's FCX was approved by the Ministry of Land, Infrastructure and Transportation.

Dec Honda delivered FCXs simultaneously in Japan and the U.S.

2003

July Honda became the world's first automaker to deliver fuel cell vehicles to a private company (Iwatani International Corporation).

Sept Honda sold FCXs to the City of San Francisco.

Oct Honda unveils the fuel cell stack "Honda FC Stack" capable of starting at 20° C below zero.



Honda FC Stack



FCX with Honda FC Stack

2004

Feb Honda implemented subzero-starting test and public-road driving test of a FCX with Honda FC Stack in Hokkaido.



Public road test in Japan

July Honda's FCX with Honda FC Stack was approved for sale by the U.S. government.

Nov Honda became the world's first automaker to sell fuel cell vehicles in a cold region, selling its FCX with Honda FC Stack to the government of the State of New York as the first step toward wider release.

Dec Honda's FCX with Honda FC Stack was approved by the Ministry of Land, Infrastructure and Transportation.

2005

Jan Honda delivered FCX with subzero starting capability to the Government of Hokkaido.

June Honda FCX received Japan's first type approval from the Ministry of Land, Infrastructure and Transportation.

June Honda became the world's first automaker to lease a fuel cell vehicle to an individual user (Mr. John Spallino in California).



FCX-V4

Oct Honda exhibited the next-gen fuel cell concept vehicle "FCX Concept" at the 39th Tokyo Auto Show.



FCX Concept

2006

Sept Honda released a video footage of the driving test of its FCX Concept, a next-generation fuel cell concept vehicle carrying a newly developed compact, high-efficiency fuel stack called "V Flow FC Stack."



V Flow FC Stack

2007

Mar Honda leased a FCX to Q'Orianka Kilcher, a 17-year-old American actress.



Nov Honda unveiled the "FCX Clarity" featuring improved dynamic performance, more spacious interior and advanced styling, at the Los Angeles Auto Show, with an eye for general release.



FCX Clarity, U.S. Version

2008

June The first FCX Clarity (U.S. version) rolled off the assembly line.



FCX Clarity, Japanese Version

July Honda unveiled the FCX Clarity, Japanese version.

July Honda started leasing FCX Clarity in the U.S.

Nov Honda FCX Clarity received the 2008 Good Design Gold Award. Honda started leasing FCX Clarity in Japan.

2009

Apr Honda FCX Clarity received the 2009 World Green Car Award.

Sept Honda delivered FCX Clarity to two private companies.

Sept FCX Clarity received the Globe Award for Fuel Cell Technology

2010

Jan Honda started field testing a next-generation home hydrogen station.



Oct FCX Clarity delivered to the Prefectural Government of Fukuoka.

2011

Jan Honda teamed up with three Japanese automakers and 10 energy companies to make a joint statement on cultivating FCV market and building hydrogen supply infrastructure in Japan by 2015.

2012

Mar Honda installed a solar hydrogen station on the premises of the Saitama Prefectural Government Building and delivered FCX Clarity with power supply function.



2013

Apr Honda started a field test involving supplying electricity from fuel cell vehicles to homes, and delivered FCX Clarity with power supply function to the City Government of Kitakyushu.



"Vehicle to Home" with FCX Clarity

Nov World premiere of Honda's new fuel cell vehicle "Honda FCEV CONCEPT" at the 2013 Los Angeles Auto Show.



Honda FCEV CONCEPT

2014

Nov World premiere of Honda's new fuel cell vehicle "FCV CONCEPT" as one of the three pillars supporting the company's Zero CO2 Emission Society vision. The other two pillars are "Power Exporter" and "Smart Hydrogen Station."



2015

Mar Honda installed a V2H compatible DC normal charger on the premises of a primary school in Saitama City, as the first practical use case embodying the company's hydrogen society concept of "Use," "Produce" and "Connect."

Oct World Premiere of the final production-ready version of Honda's new fuel cell vehicle "Clarity Fuel Cell" at the 44th Tokyo Auto Show in 2015.

Dec Honda installed its packaged "Smart Hydrogen Station" on the premises of its Wako Head Office Building.



2016

Jan Honda unveiled its plan to sell the "Clarity Fuel Cell" in the U.S. at the Washington D.C. Auto Show.



Clarity Fuel Cell (production version)

Dec The first U.S. customers take delivery of their Clarity Fuel Cells.



Main Features

Safety Features/Driving Assist

- Honda Sensing™ (CMBS <Collision Mitigation Braking System>, ACC <Adaptive Cruise Control> with low speed follow, LKAS <Lane Keeping Assist System>, RDM <Road Departure Mitigation> System w/ Lane Departure Warning)
- Lane Watch
- Agile Handling Assist
- Motion adaptive EPS
- 9-lamp full-LED headlight <in-line type> (with high/low beam, auto leveling/auto light control mechanisms)
- Emergency stop signal
- Hill start assist function
- Approaching-vehicle notification system
- Driver & passenger-side i-SRS airbag systems
- Front i-side airbag system + side curtain airbag system (covering front/rear rear seats)
- Driver-side SRS knee airbag system
- Electronically controlled parking brake

Comfort Features/Meters

- 8" Display Audio w/ hi-res (800x480) WVGA electrostatic touch-screen
- 540-watt premium audio system w/ 12 speakers incl. subwoofer
- Head-up display
- Digital graphic meters (power/charge meter, speedometer, fuel cell generation monitor, high-voltage battery level meter, fuel meter, etc.)
- FCV telematics
- Active noise control
- Intelligent dual full-auto air conditioner (left/right independent temperature control with GPS-controlled uneven solar radiation control/plasma cluster technology/automatic recirculation/fresh-air mode switching mechanism with emission gas sensing)
- HondaLink®, HD Radio™, Apple CarPlay™, Android Auto™
- Honda smart key system (2 keys with A/C on/off function)
- Telescopic & tilt steering
- Allergen-free high-performance deodorizing filter
- One-touch power window for all doors (with anti-pinch mechanism/key-off operation mechanism)
- Auto brake hold function
- USB jack (2 jacks <1.5 A, 1.0 A> in front console)
- Accessory socket (12 VDC) <in front console/rear>
- Headlight auto-off function
- Electric gear selector

Interior

- Combination seat trim (genuine leather x Prime Smooth)
- Heated seats (driver and front passenger)
- 8-way power driver seat (slide/recline/height adjustment/forward & backward, with memory function)
- 4-way power passenger seat (slide/recline)
- Steering wheel with genuine leather (smooth leather)
- Black wood grain inserts on console and doors
- Ultrasuede® (instrument panel middle pad/door lining)
- Auto anti-glare rearview mirror
- LED foot lamp for front seat
- Vanity mirror with sunvisor (illuminated) for driver seat/passenger
- Back pocket & smartphone pocket for driver seat/passenger seat
- High-deck center console (console box with drink holders/large armrests)

Exterior/Glass

- Aluminum doors, fenders, hood and trunk
- Body-colored decklid spoiler
- Acoustic glass (front windshield/all doors <except front quarter glass>)
- Heat-absorbing, UV-shield glass (front windshield/front doors)
- Heat-absorbing, UV-shield tinted glass (rear doors/rear quarter windows/rear windshield)
- Half-shade front windows
- Roof-mounted fin-type antenna
- Smart clear wipers (vehicle speed-linked intermittent mode/variable intermittent mode/built-in washer nozzle/mist mechanism/rain sensor)
- Retractable, remote-controlled, colored power door mirrors (with LED turn signal indicator/auto retractable mirror)
- LED position lamps (with accessory lamp function)
- Full-LED rear combination lamps
- Front fender garnish
- Lid-type external power supply port (CHAdEMO terminal)

Suspension, Tires/Wheels, Brakes

- 18-inch aluminum wheels
- 235/45R18 94W steel radial tires
- SPORT mode switch
- Power servo braking system
- Emergency flat tire repair kit (no spare tire)

Specifications

Drive Method	FF	
Vehicle name/model	Clarity Fuel Cell	
Dimensions/weight/maximum passenger capacity	OAL / OAW / OAH (in)	193.5" / 73.8" / 58.3"
	Wheelbase (in)	108.3
Track (in), front/rear	62.2" / 62.4"	
	Ground clearance (in)	5.3"
Vehicle weight (lbs)	4167	
Seating Capacity	5	
Cabin dimensions (in), L/W/H	76.8" / 62.2" / 45.7"	
	Model	MCF4
Motor	Type	AC synchronized motor
	Type	Polymer Electrolyte Fuel Cell (PEFC)
Fuel/tanks	Fuel type	Compressed hydrogen
	Number of tanks	2
Hydrogen Storage Capacity	5.46 kg	
	Nominal service pressure	10,000 psi (70 MPa)
Performance	Fuel cell stack	138
	Motor	174 @ 4,501-9,028 rpm [max rpm: 13,000]
Max torque (lb ft/rpm)	221 @ 0-3,500 rpm	
	Min turning radius (ft)	18.7
Drive battery	Type	Lithium ion battery
Powerplant transmission/running systems	Final gear ratio	9.333
	Steering system type	Hook/pinion type (Power steering specification)
Tire, front/rear	235/45R18 94W	
	Main brake type/model, front/rear	Hydraulic ventilated disk/hydraulic disk
Suspension type, front/rear	McPherson type/multi-link (wishbone) type	
Stabilizer type, front/rear	Torsion-bar type	

The vehicles denoted by a star (☆) are eligible for vehicle purchase tax, vehicle weight tax and vehicle tax reliefs. (The vehicle must be new and registered on or before March 31, 2017 to be eligible for purchase tax relief, on or before April 30, 2017 to be eligible for weight tax relief, and on or before March 31, 2016 to be eligible for vehicle tax relief. Each tax relief is applied in the tax year following the year of vehicle registration.)

■ The main specifications represent the values reported in the new vehicle application form pursuant to the Road Trucking Vehicle Act. ■ CLARITY, Allergen-free, FCX, Honda Sensing, HondaLink, LaneWatch, IKAS, Power Creator, Power Exporter and SHS are trademarks of Honda Motor Company. ■ AllerCatcher* is a trademark of Daiwabo Holdings Co., Ltd. ■ TRIPLE FRESH* is a trademark of Suminoe Textile Co., Ltd. ■ The Plasmacluster logos and Plasmacluster are trademarks of Sharp Corporation. ■ AppleCarPlay™, iOS and iPhone® are trademarks or registered trademarks of Apple Inc. in the U.S. and other countries. ■ Bluetooth® is a registered trademark of U.S. Bluetooth SIG, Inc. ■ HDMI®, the HDMI® logos, and High-Definition Multimedia Interface, are trademarks or registered trademarks of HDMI Licensing, LLC in the U.S. and other countries. ■ Ultrasuede® is a registered trademark of Toray Industries, Inc. ■ VICIS is a registered trademark of the Vehicle Information and Communication System Center. ■ Manufacturer: Honda Motor Company

Illustration of Dimensions Unit: inches

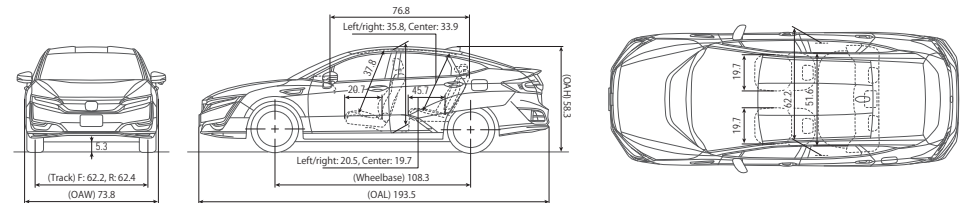

+ The specifications and features are subject to change without notice.

+ The colors shown in the photographs featured in this brochure may be different from the actual colors.

+ All photographs of the interior are based on body cutouts.

+ The meters are illuminated for the purpose of photographing.

+ The screen images are simulated.



BLUE SKIES FOR
OUR CHILDREN

CLARITY
FUEL CELL

Press Information | March 2017

